



GAME

RoboJackets



Final Competition

REMINDER!

- Saturday, November 14, 2009!
- FTC Scrimmage
- Free food!



Final Competition

- **Schedule**

- 8:30 AM – Teams Arrive & Setup
- 9:15 AM – Opening
- 9:35 AM – Free Practice
- 10:45 AM – Matches
- 11:45 AM – Lunch
- 12:45 PM – Matches
- 2:45 PM – Closing and Awards
- 3:30 PM – Everybody is outta here!



FTC Competition

video



NUMBERS



Data Types

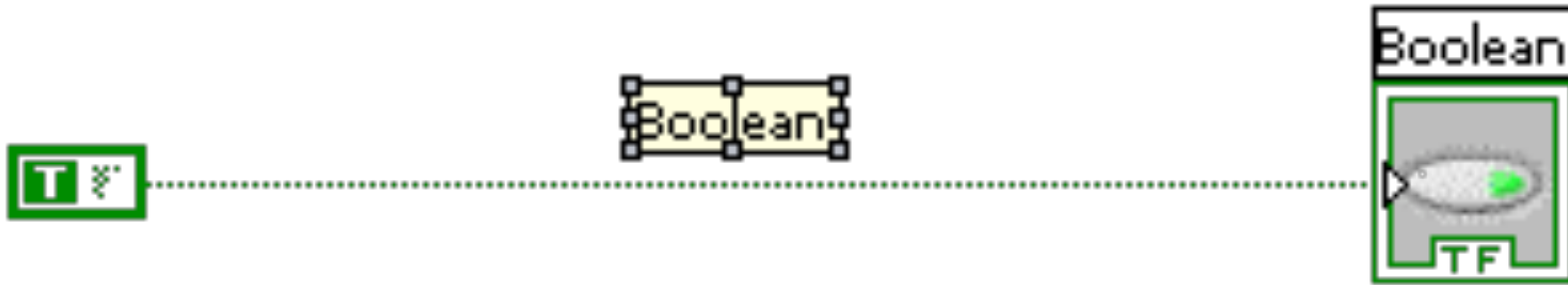



Data Types

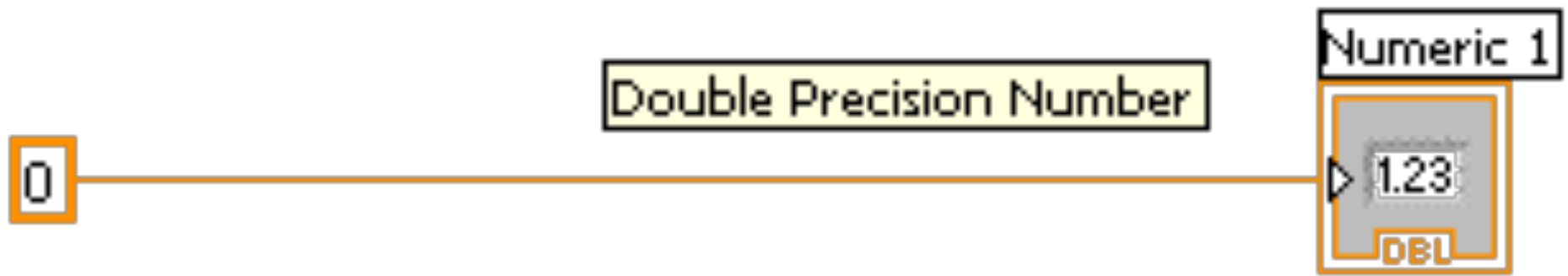



Data Types

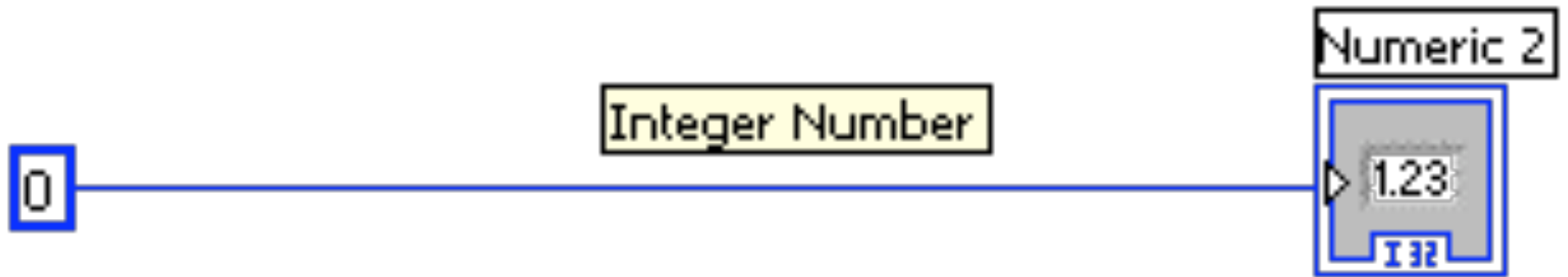



Data Types

0 + 0i

Complex Number

Numeric 3

1.23

CXT



Data Types

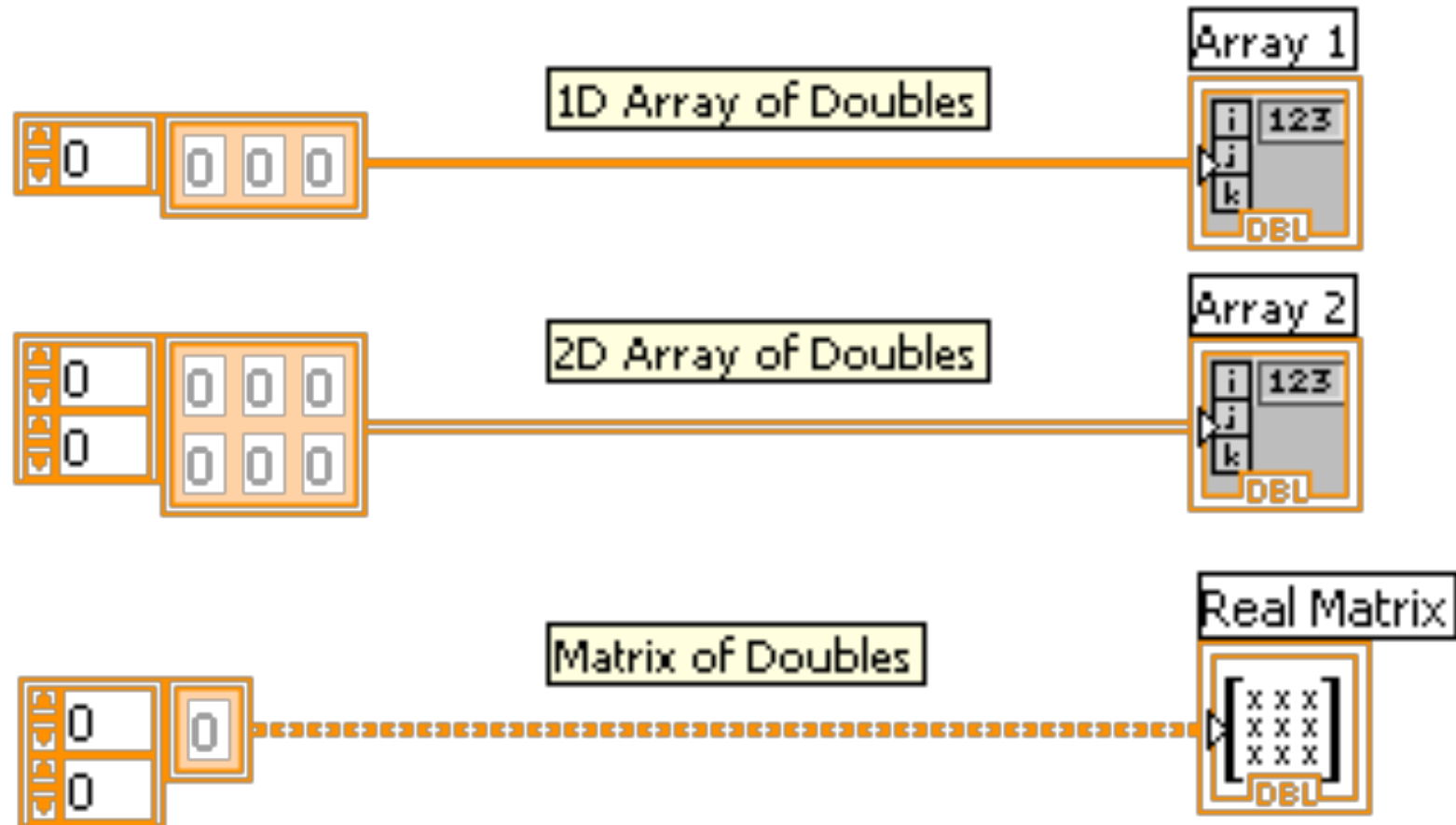



Data Types

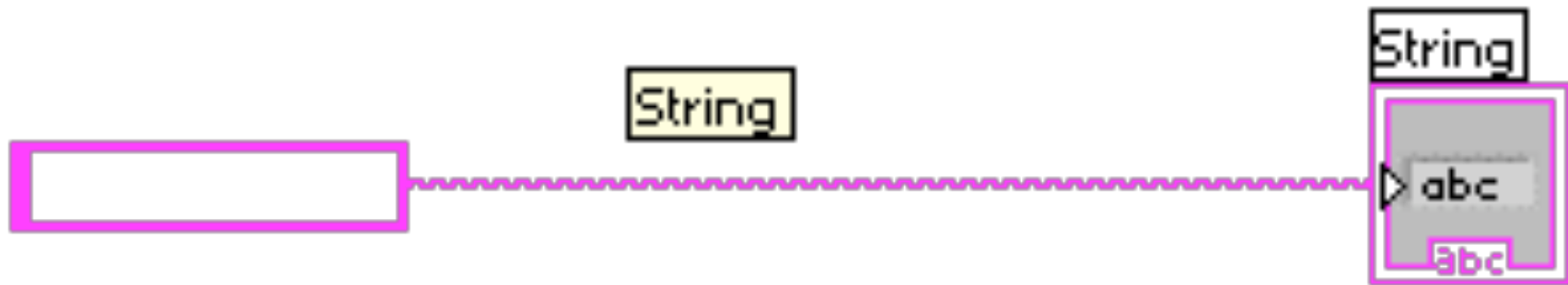



MATH

RoboJackets



Numeric

Numeric
Boolean
String

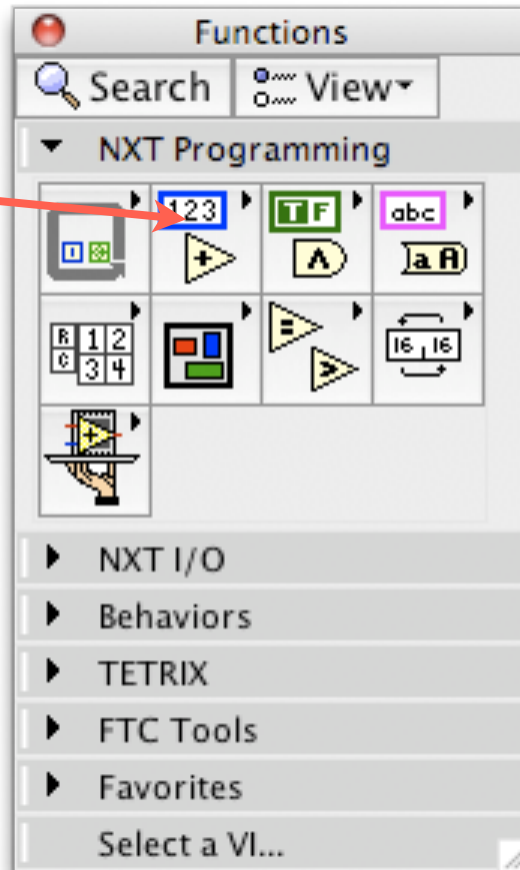

Array
Cluster
Comparison



Numeric

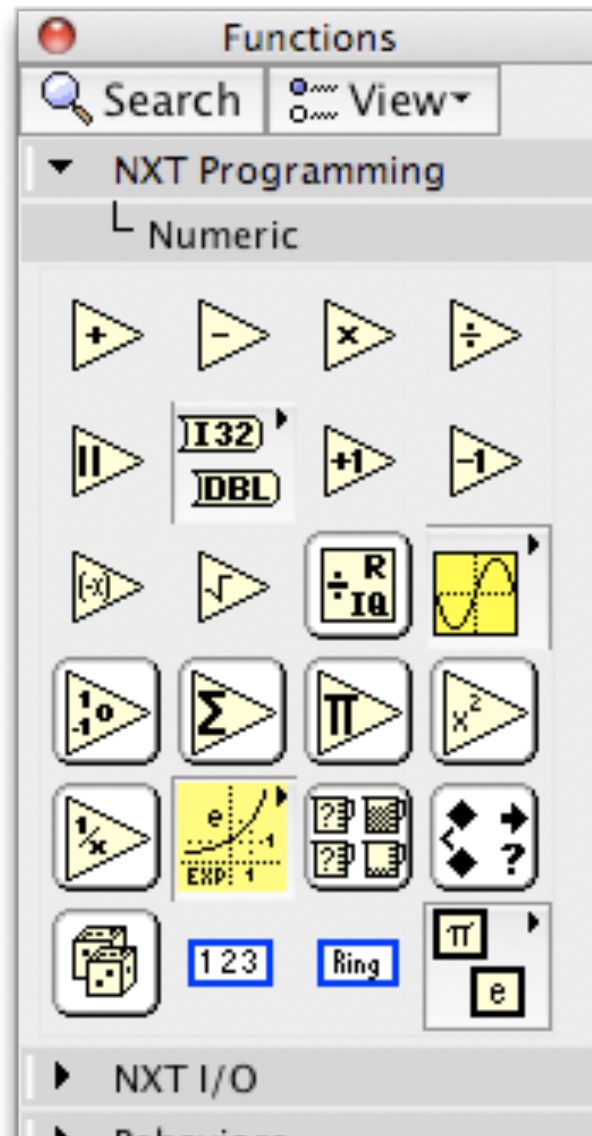



Boolean

Numeric
Boolean
String

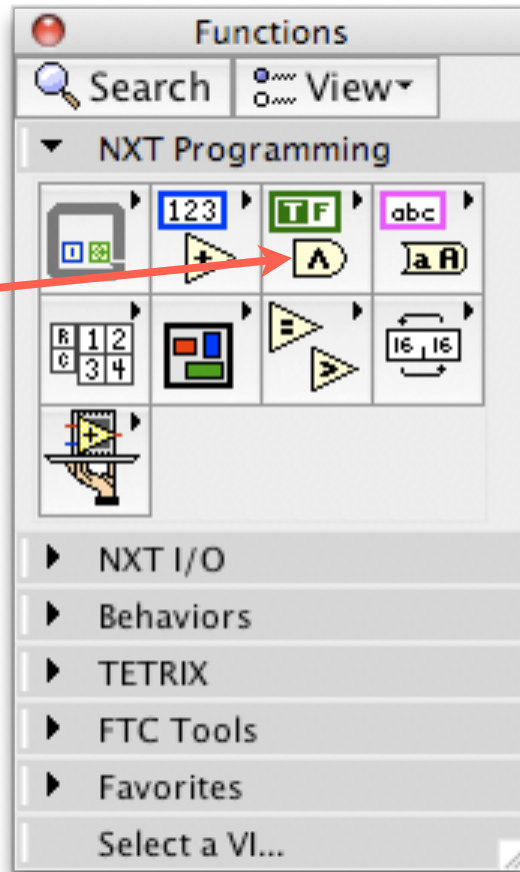

Array
Cluster
Comparison



Boolean

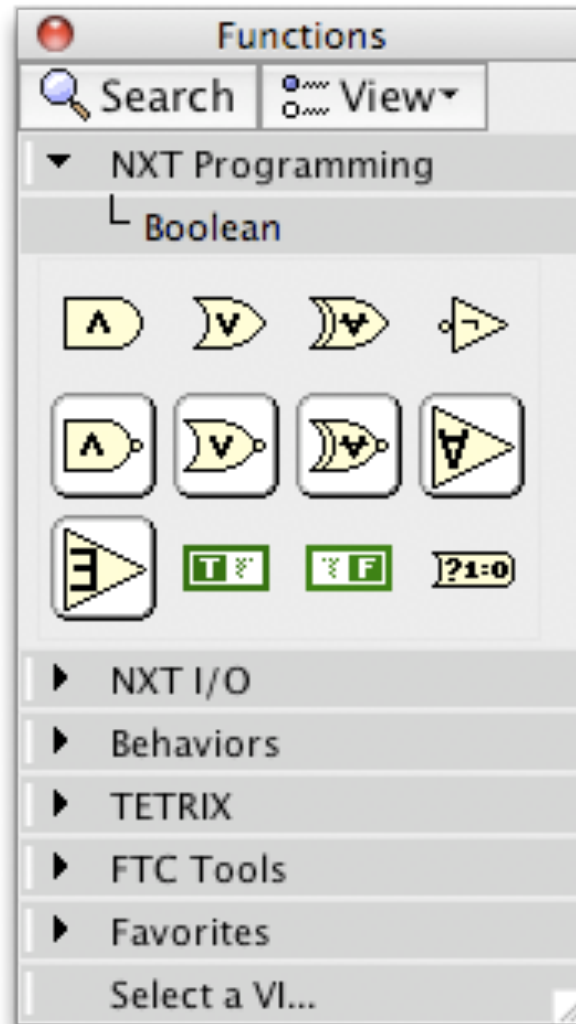



String

Numeric
Boolean
String

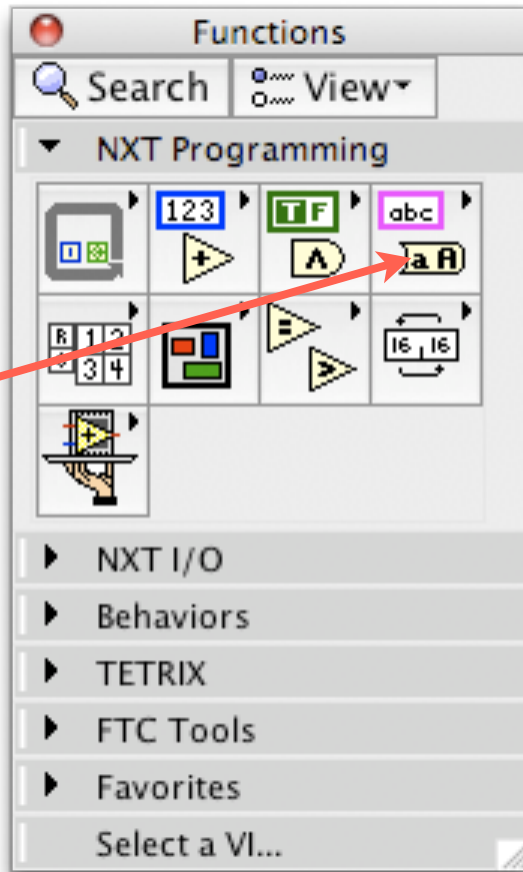

Array
Cluster
Comparison



String

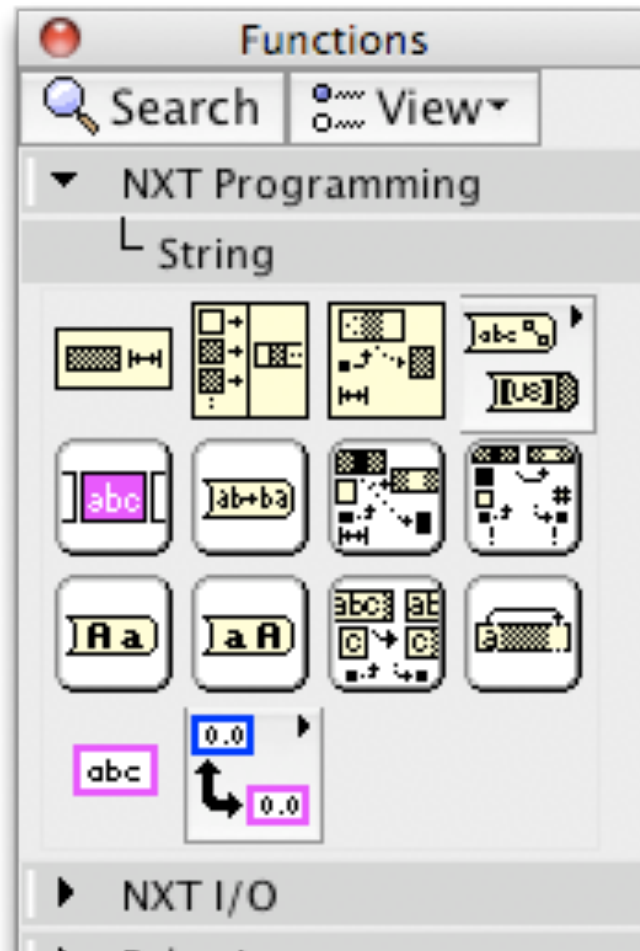



Math

Numeric
Boolean
String

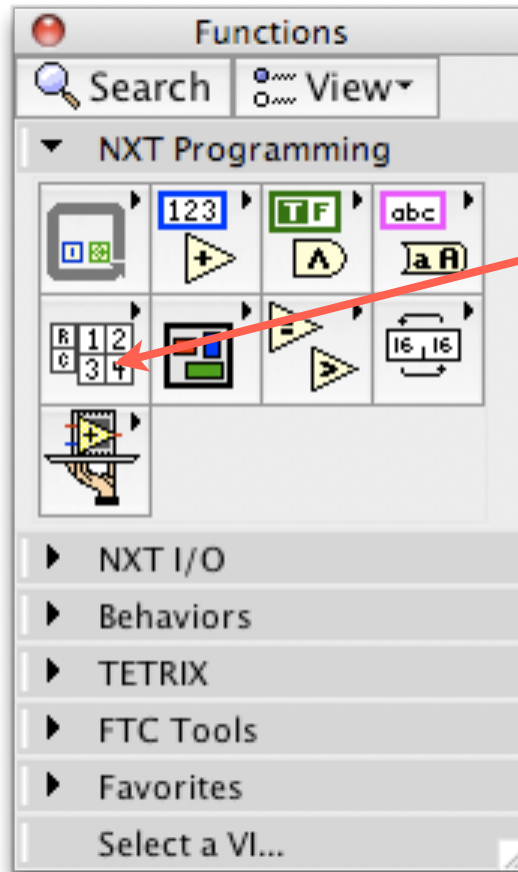

Array
Cluster
Comparison



Array

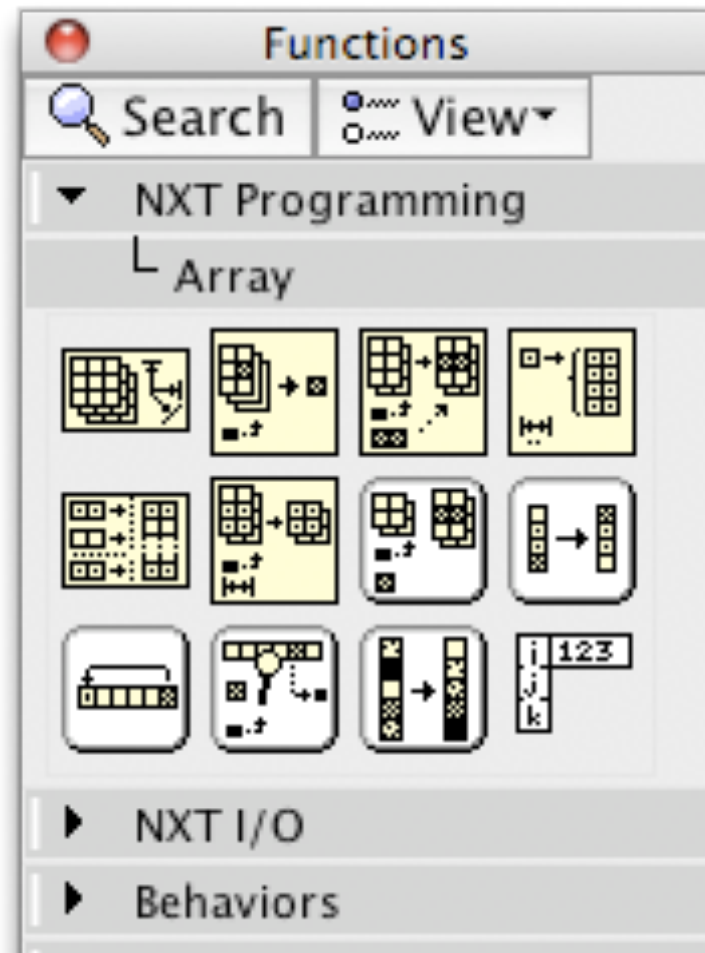



Cluster

Numeric
Boolean
String

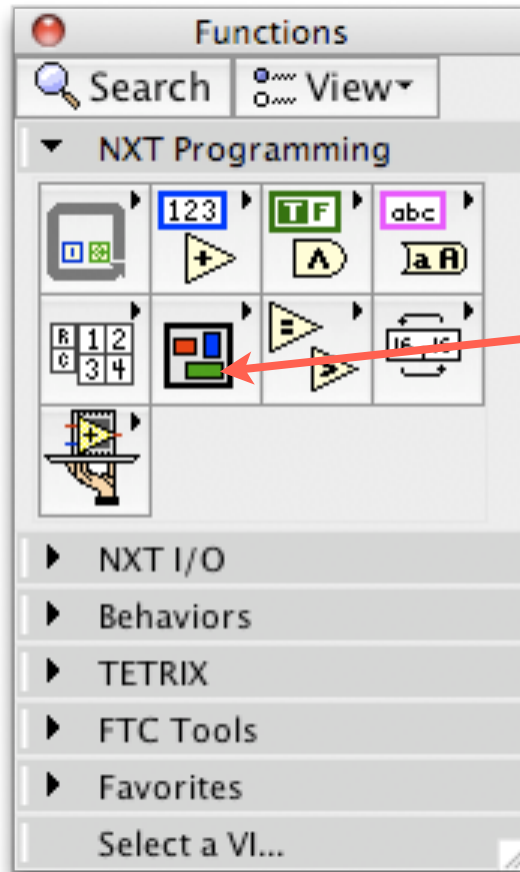

Array
Cluster
Comparison



Cluster

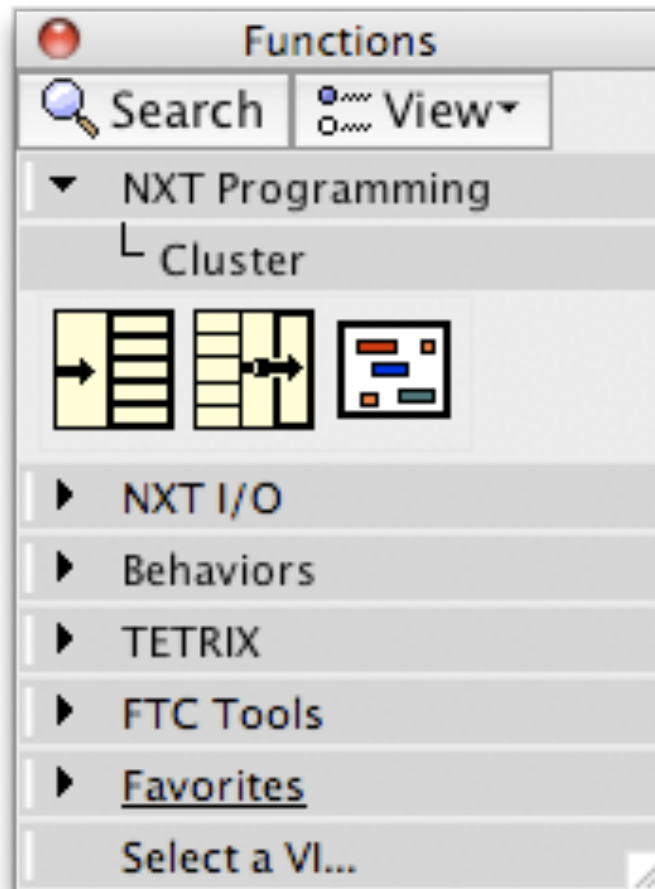



Math

Numeric
Boolean
String

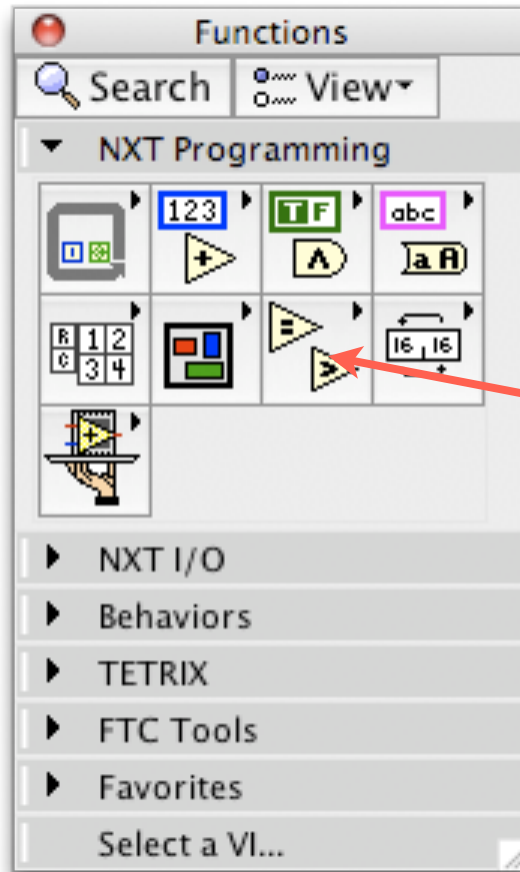

Array
Cluster
Comparison



Comparison

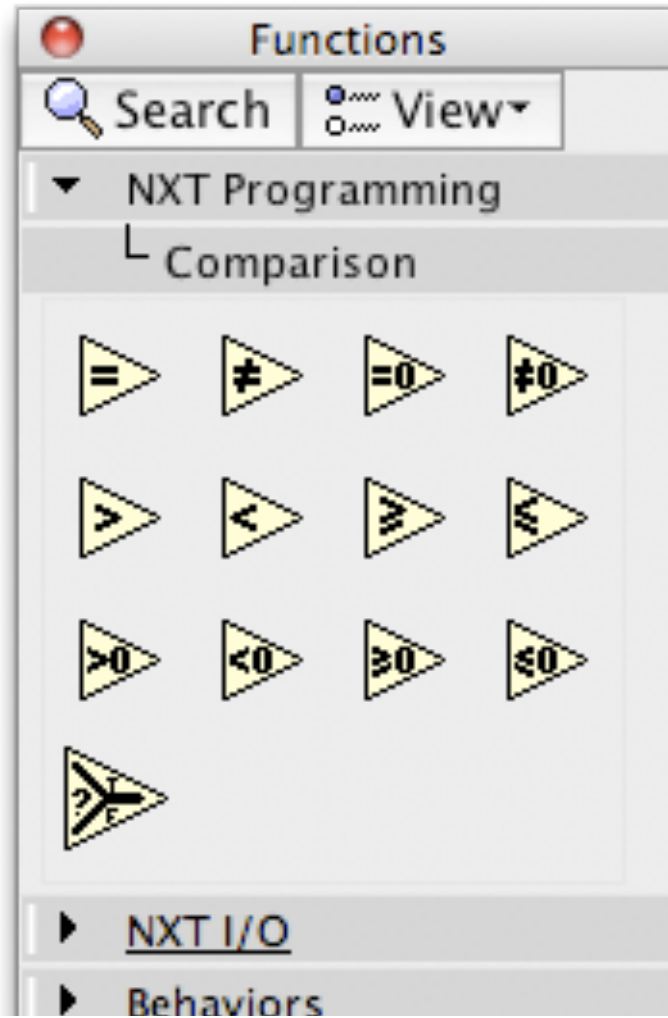



SENSORS



Sensors

- Touch
- Light (previously)
- Ultrasonic (Distance)
- Sound
- Wheel Position (encoding)



Touch Sensor

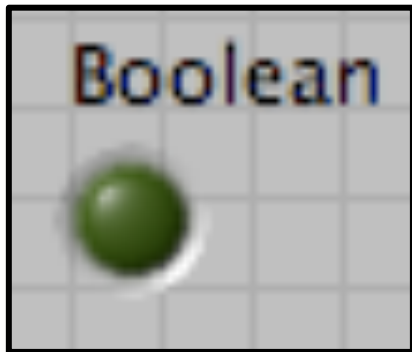

Port 4 ▼

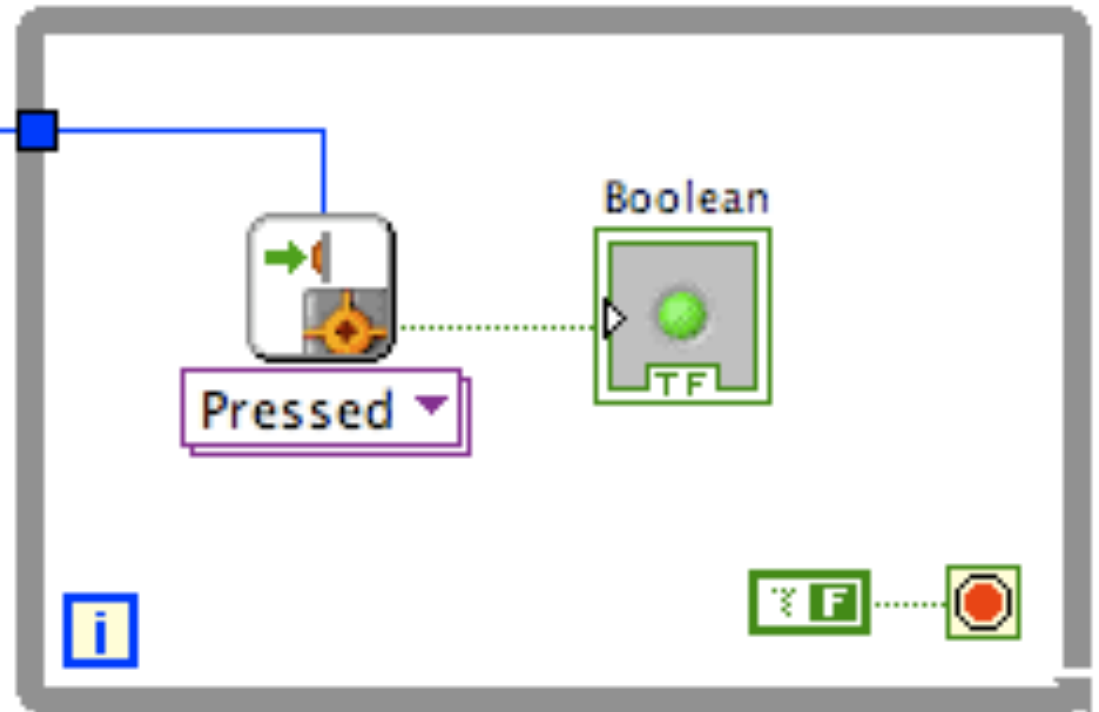



Touch Sensor

Add a waveform chart!

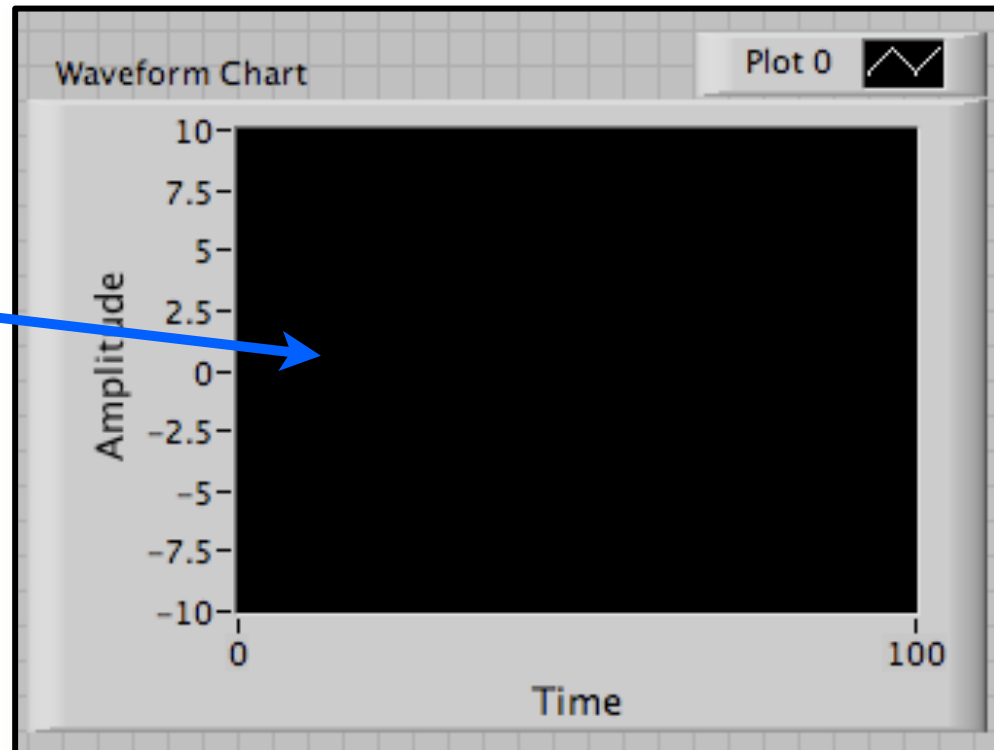
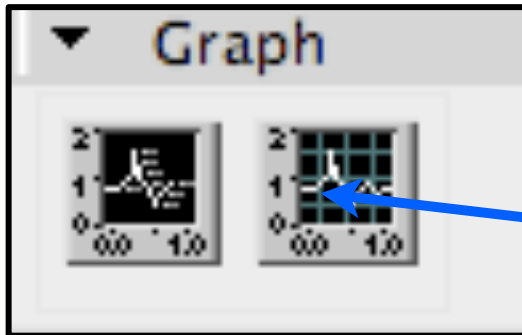



Touch Sensor & Math

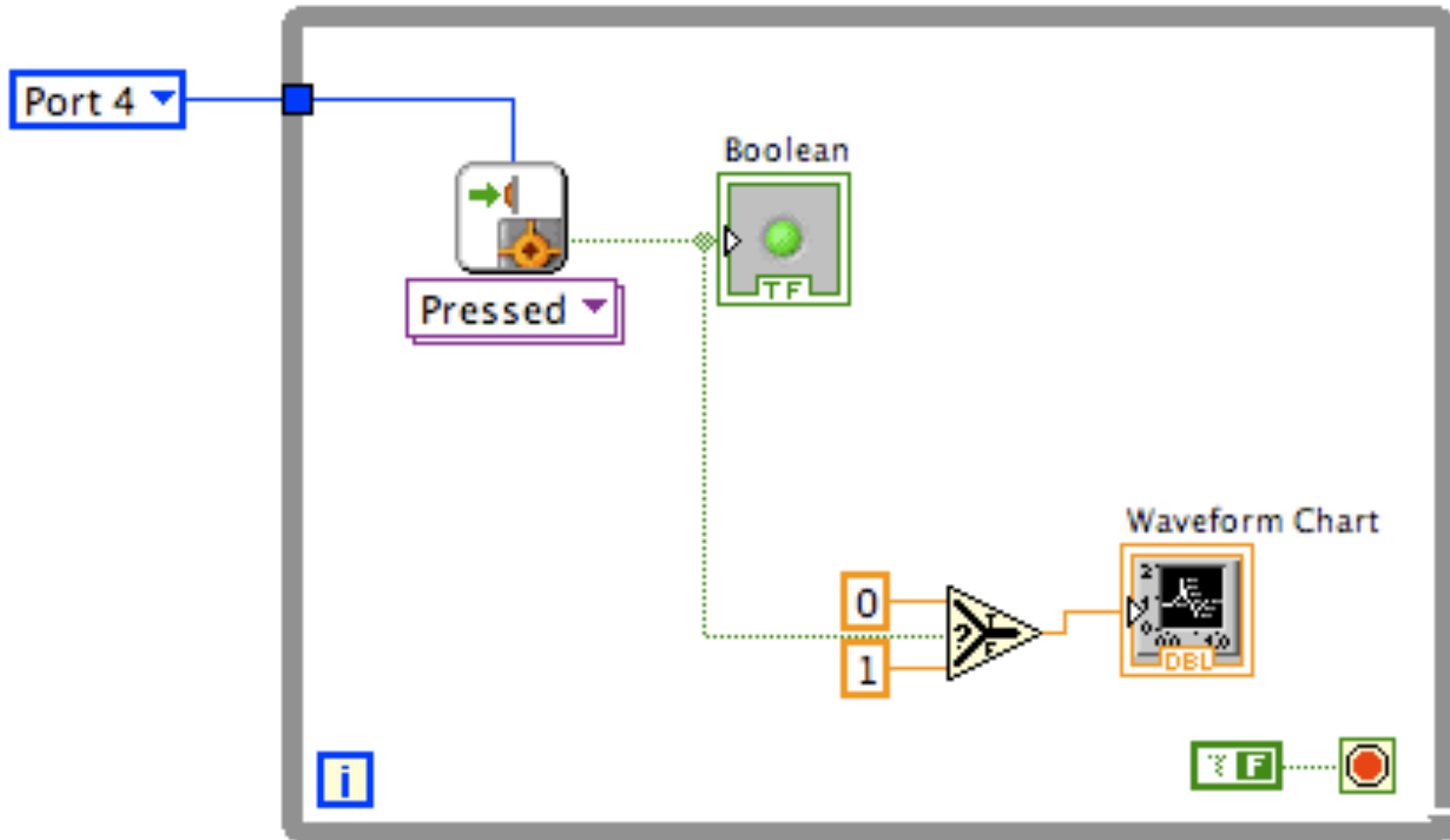



Light Sensor



Let's do another demo!

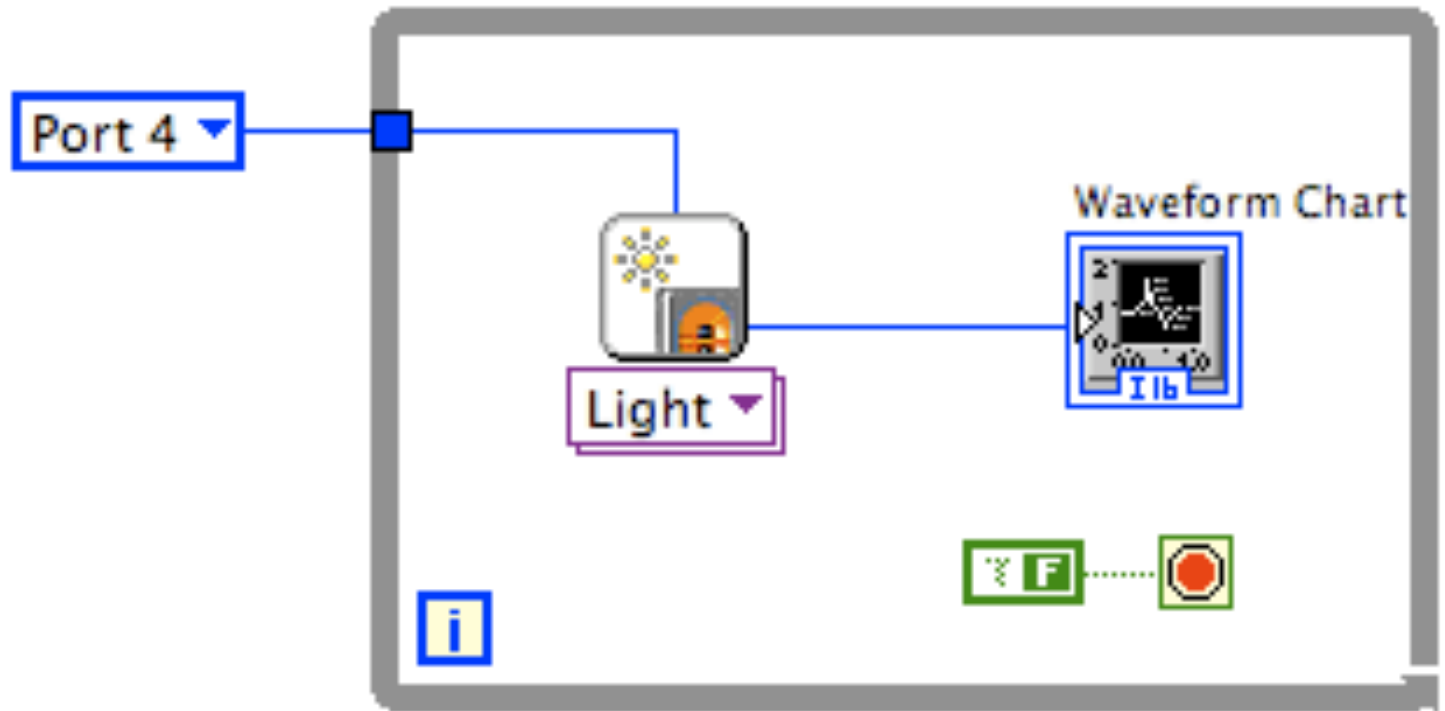



Sound Sensor



Let's do another demo!

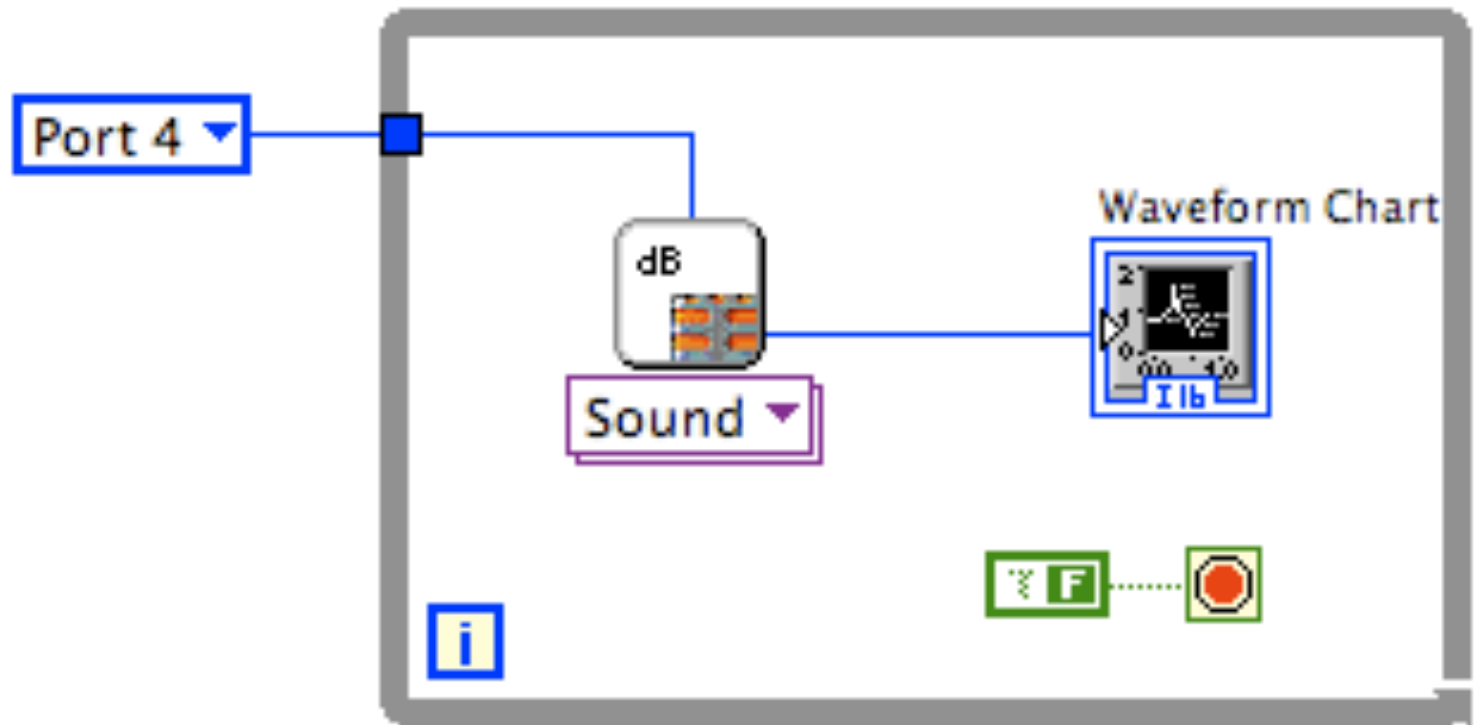



Ultrasonic Sensor

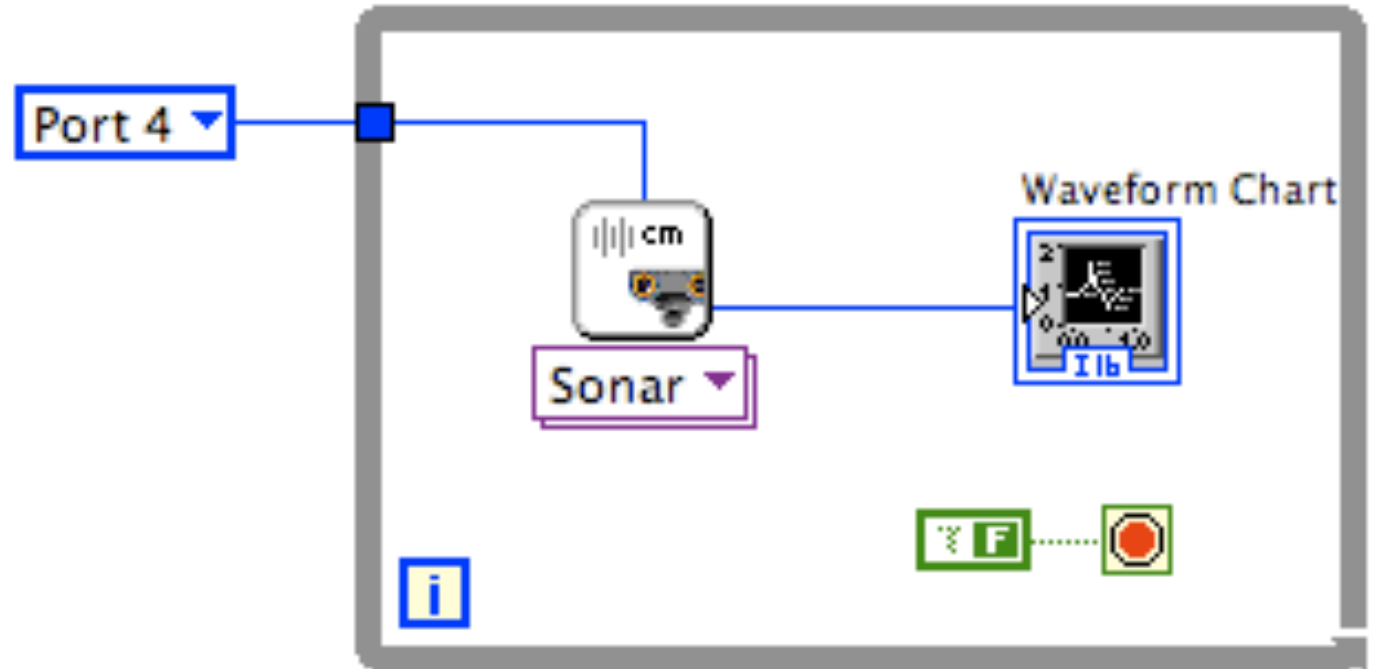



Ultrasonic Sensor

Theremin!

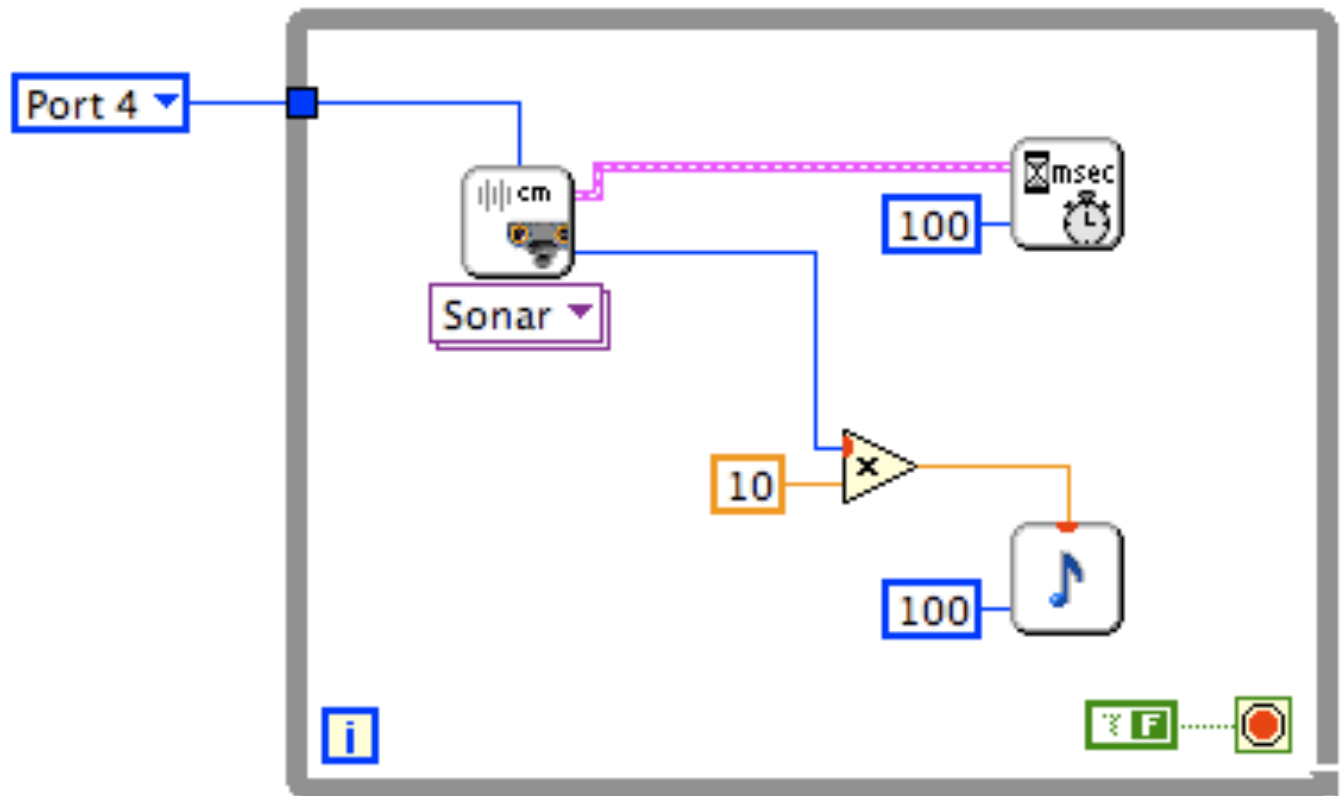



Rotation Sensor

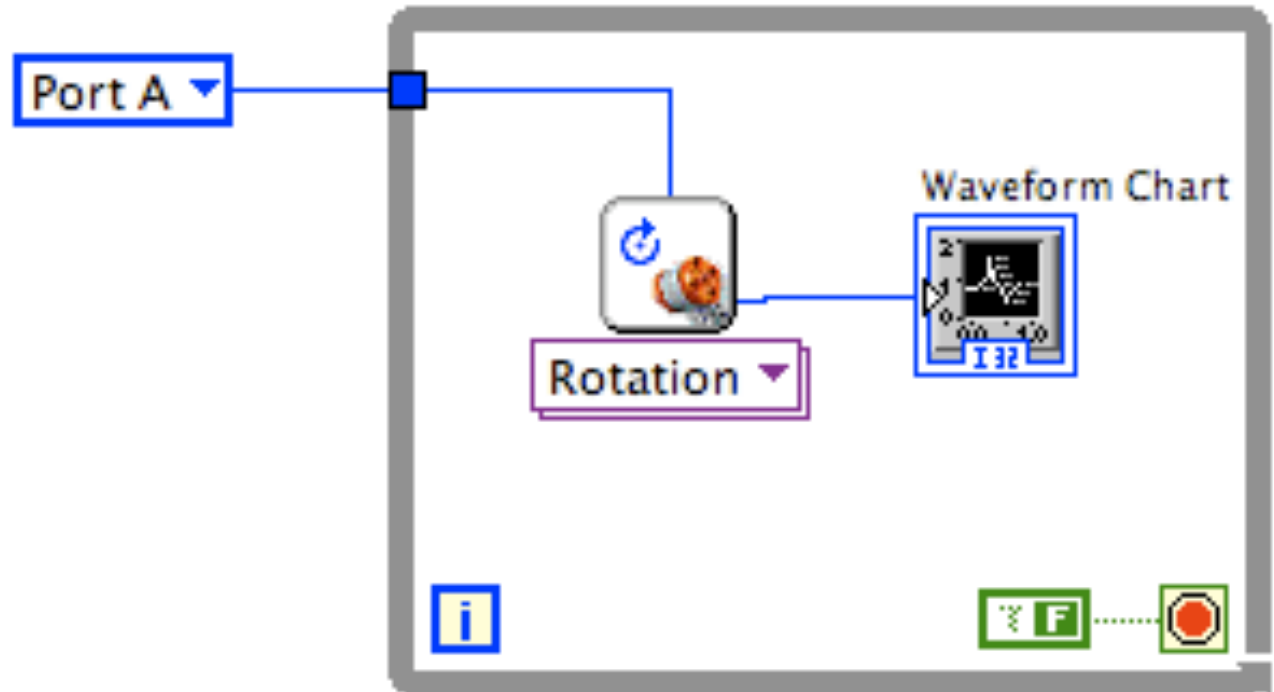
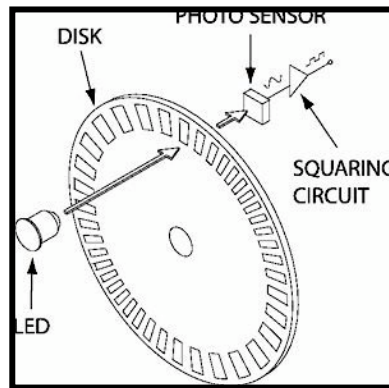



Rotation Sensor

Etch-A-Sketch!

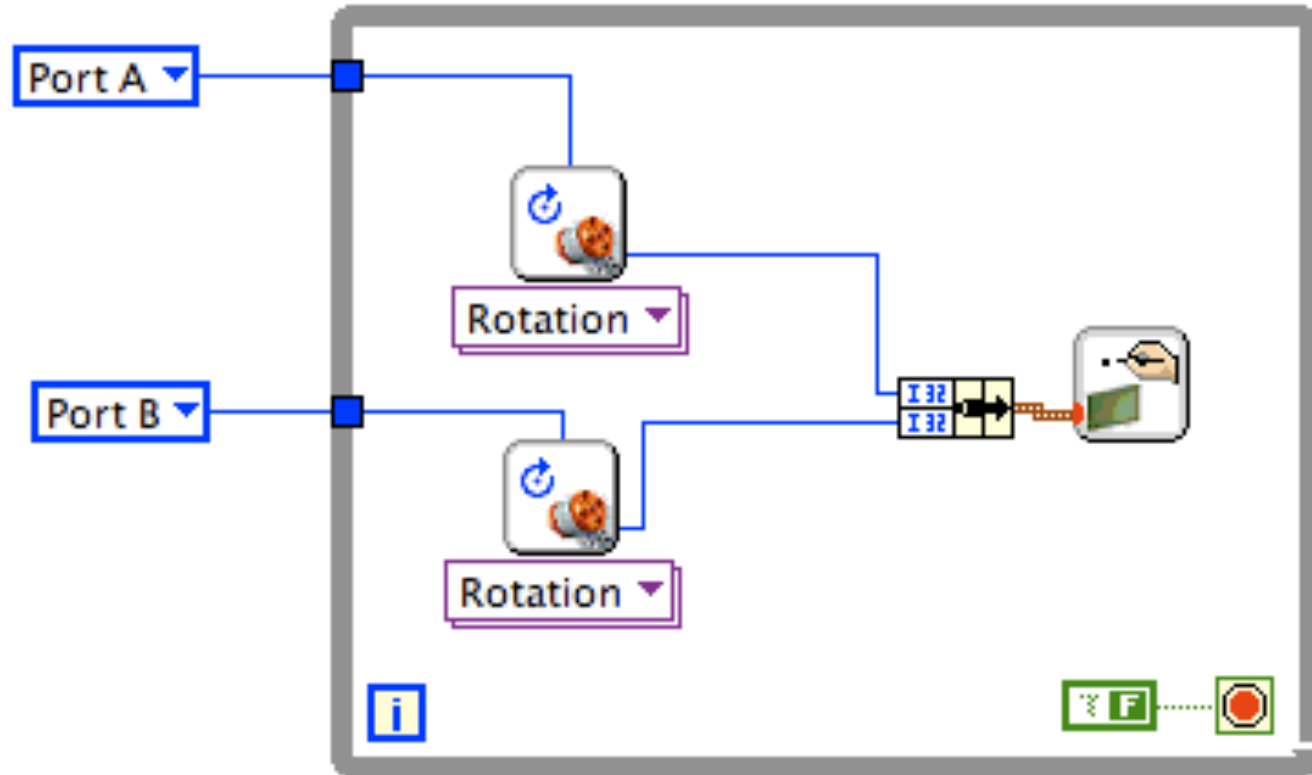



DRIVE BASE



Drive Base

Put together a drive base usable
for the final competition



Drive Base

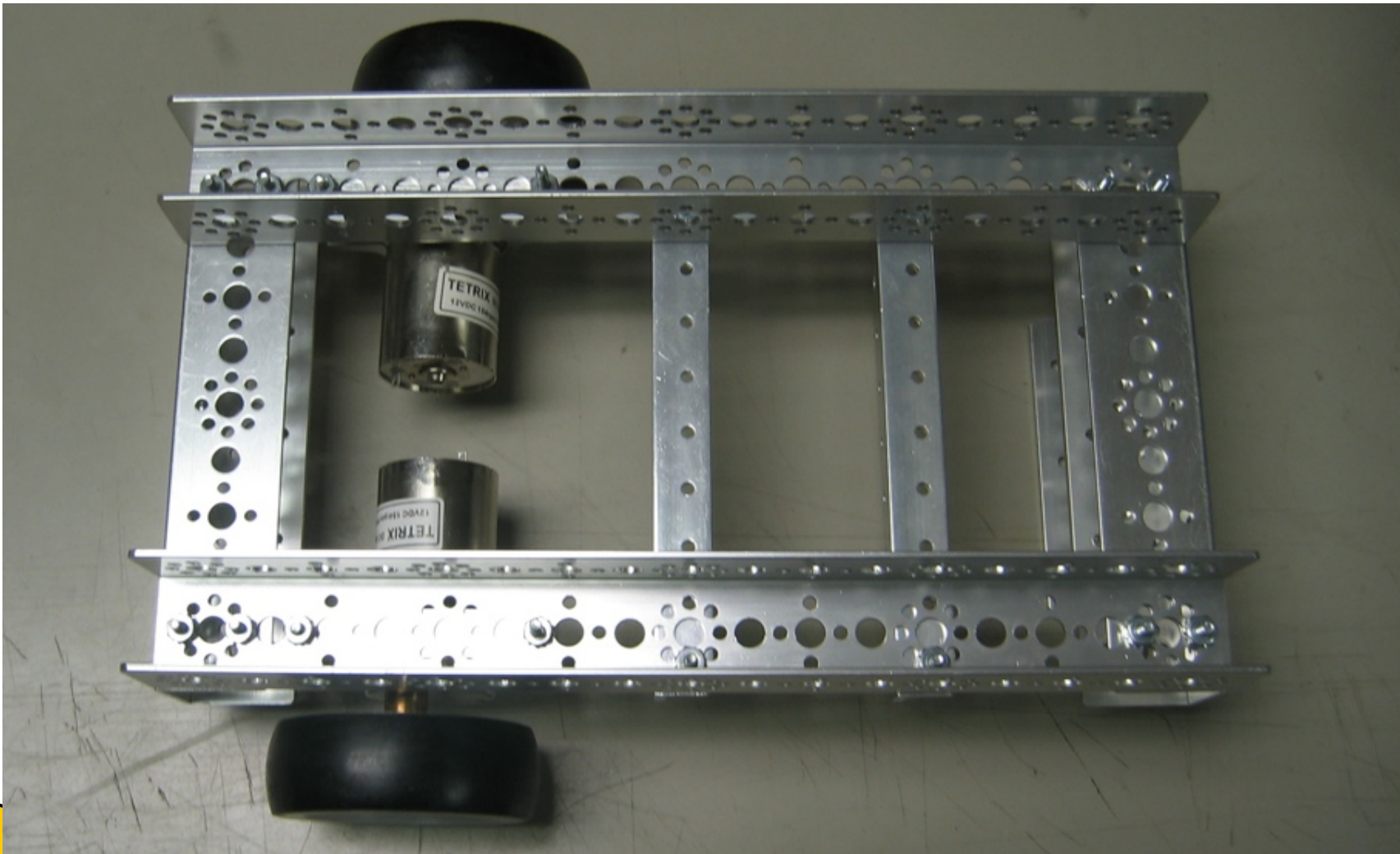



Drive Base

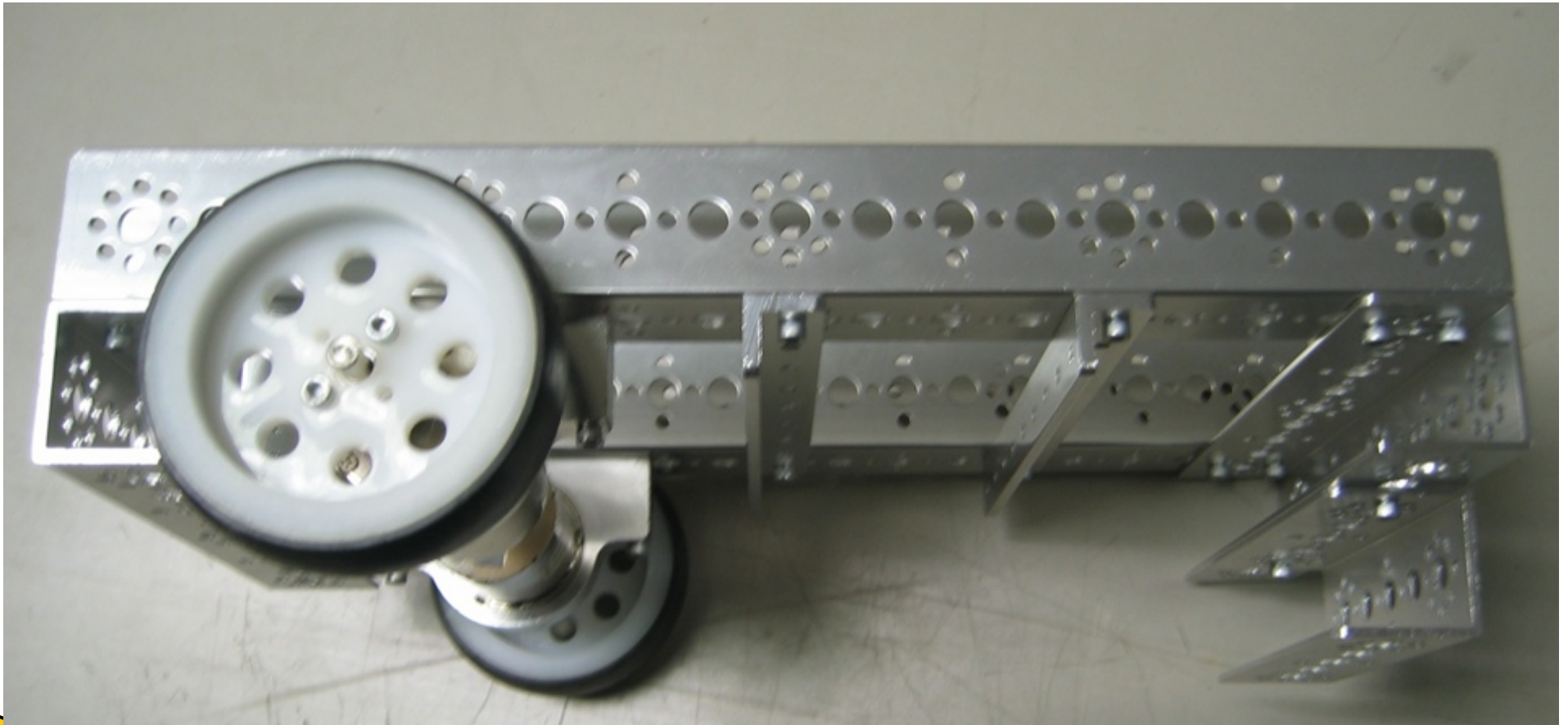



Drive Base

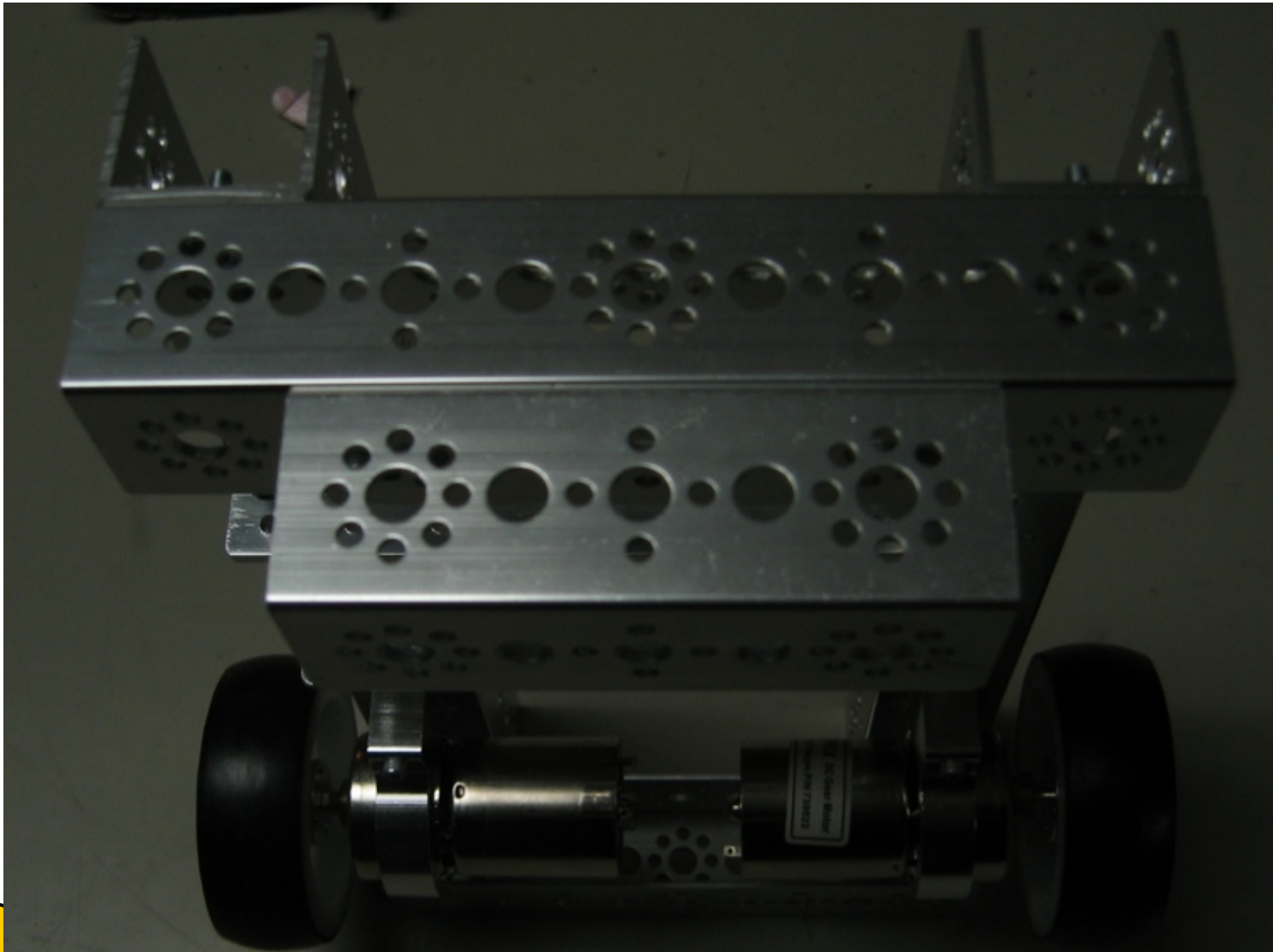



Drive Base

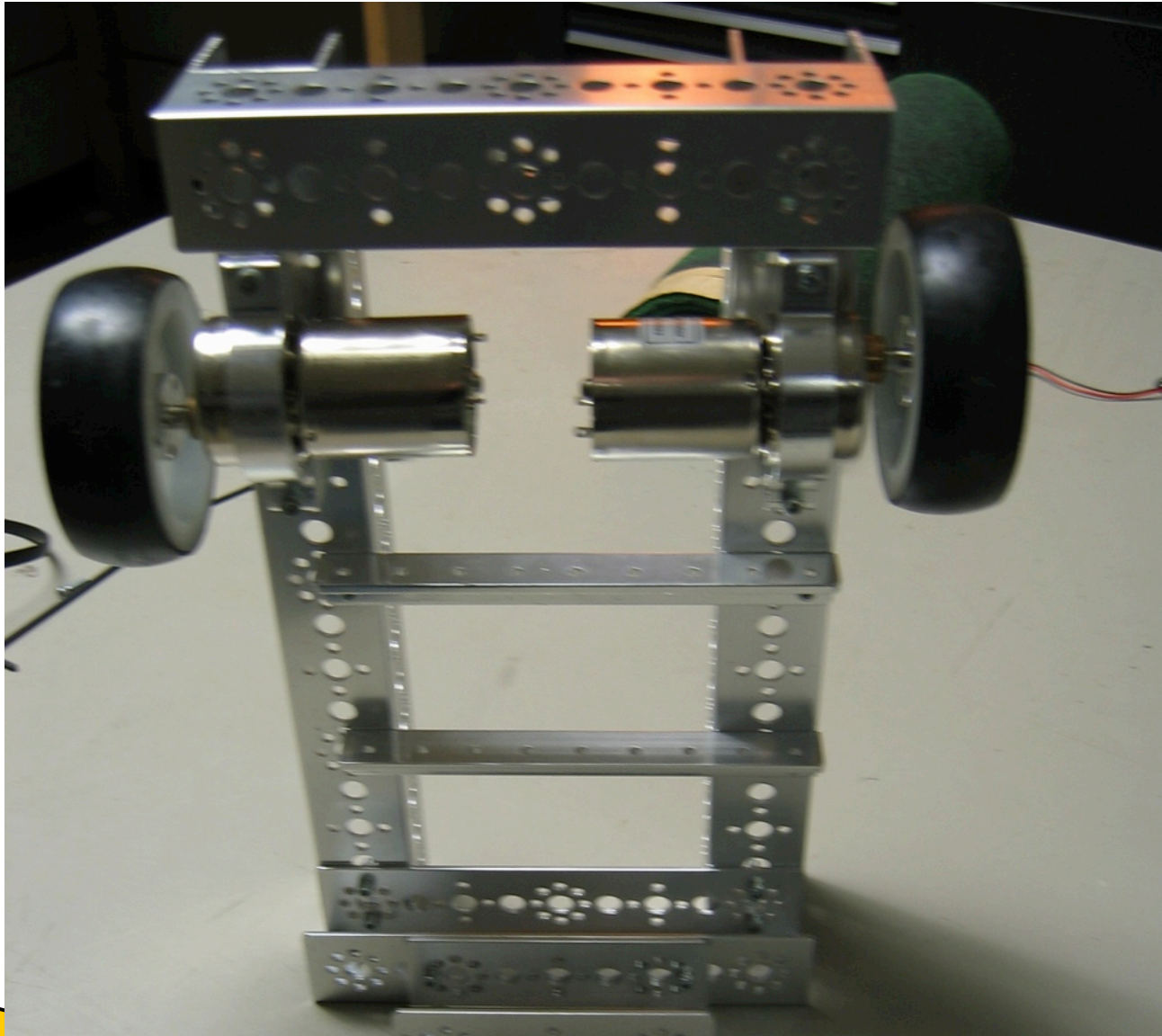



Drive Base





ACTIVITY