

# Robot Quick Build Session 2009



## FRC Control System & Electrical Assembly

Produced by

Ken York, Team 476

Ed Latimer, Team 476

Ron Markum, Team 1750

Special Thanks to



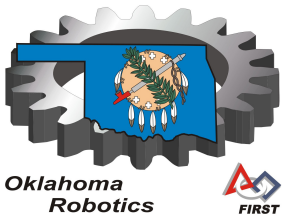

Oklahoma State University





# Overview



-  During the next two and a half hours students will assemble and test the control system.
-  During the first hour the layout and installation of the components and wiring on to the base plate should be completed.
-  At hour two you should be joined by someone from the programming group who will install the software upgrades and set up the tethered and wireless communications.
-  You should have the required components of the KOP and RQBS parts with you and ready to assemble.
-  After completion, the electrical assembly will be taken to the frame area and mounted onto the robot chassis.



Oklahoma  
Robotics



FIRST

# The Goal

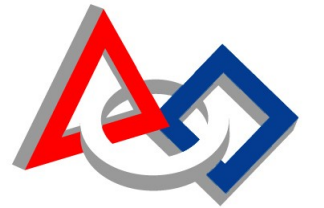

**FIRST**®

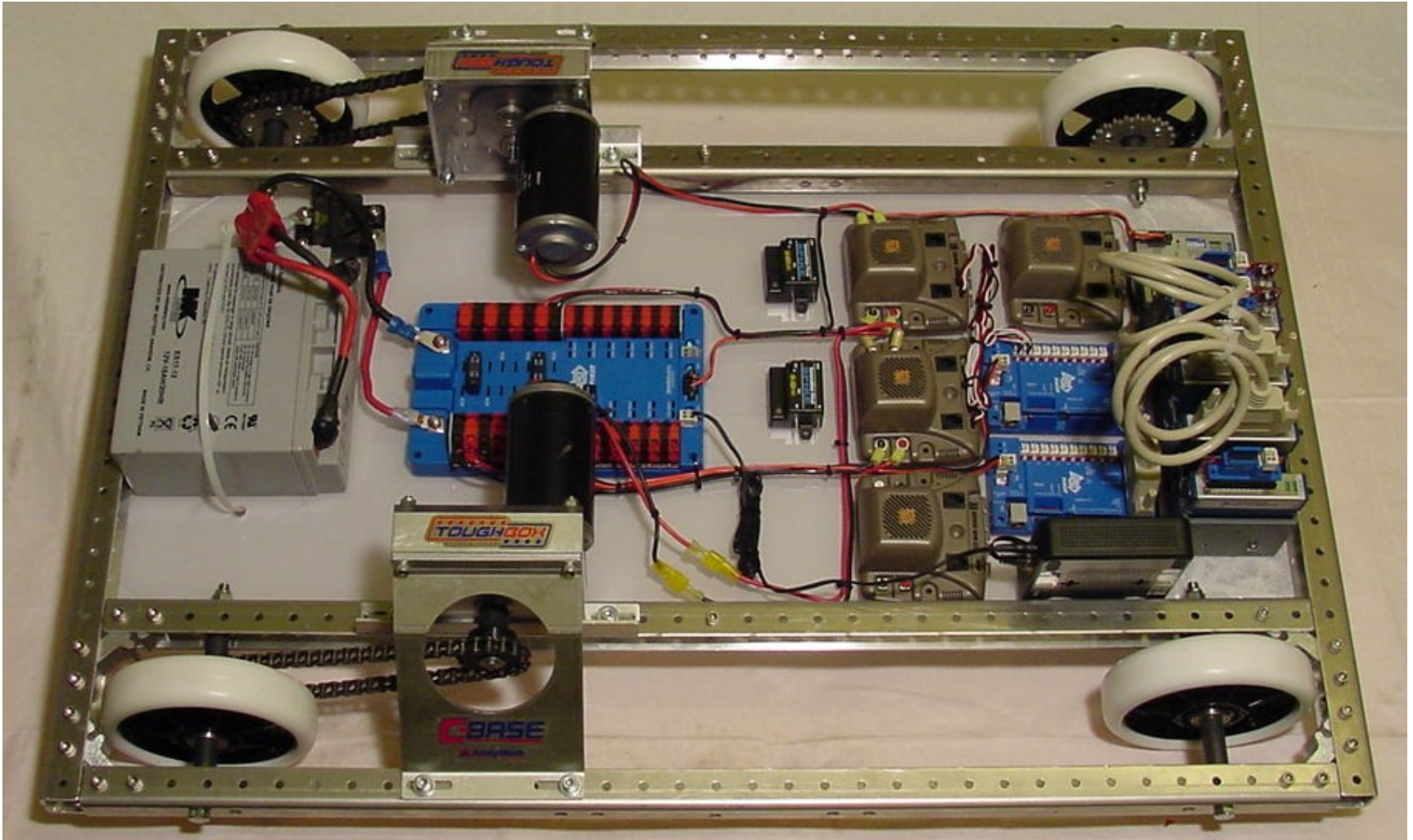

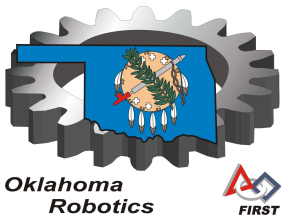

# Check the Parts



- Locate the Control System Box.
- Inventory the contents. Report any missing components.
- Locate the 120 amp circuit breaker. \*
- Locate the QD battery connectors.\*
- Locate the wiring terminals.\*
- Locate the RQBS base plate and bag.

\*Located in one of the tote boxes. Refer to KOP inventory sheets.



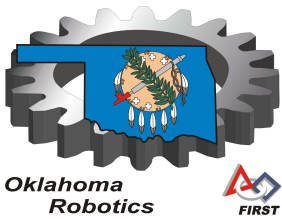

# Required Tools



 **Safety Glasses, put them on now.**

 Wire strippers

 Wire cutters

 Wire crimpers

 Phillips screwdriver - #2

 Flat Screwdriver

 Supplied Wago flat screwdriver

 7/16" combination wrench

 3/8" combination wrench

 10mm combination wrench

 Tape measure

 1/4" and 3/8" Drills

 Cordless drill





Oklahoma  
Robotics



# Required Control System Items (robot)





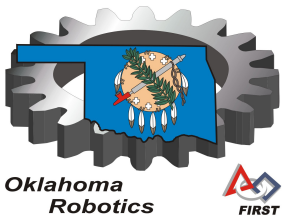

-  Place the following items on a clear workspace.
-  cRIO and modules, power distribution board, Jaguar controllers, digital sidecars, 120 amp breaker, 2 PWM cables, 2 CIM motors, Ethernet cable, connector bag, 2 DB37 cables, and extra 10 and 14 gauge wire.





# Read Instructions!



-  Peruse sections 1-5 of the 2009 Control System Manual.
-  Read section 2 carefully.
-  Do not connect battery until instructed.
-  Make all electrical connections and ensure CIM motors are secured and safe to operate before powering any part of the control system.
-  Refer to the large 2009 FRC Control System layout included in the control system box.

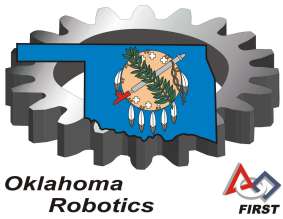

# Layout



 Use the provided drilling templates, drill  $\frac{1}{4}$ " and  $\frac{3}{8}$ " holes as indicated. Accurately place templates on the base plate and tape in place. Verify the 32" spacing dimension between the two template holes.

 See the pictures in the next two slides.





Oklahoma  
Robotics



# Drill Holes in Base Plate



Front Drill  
Template

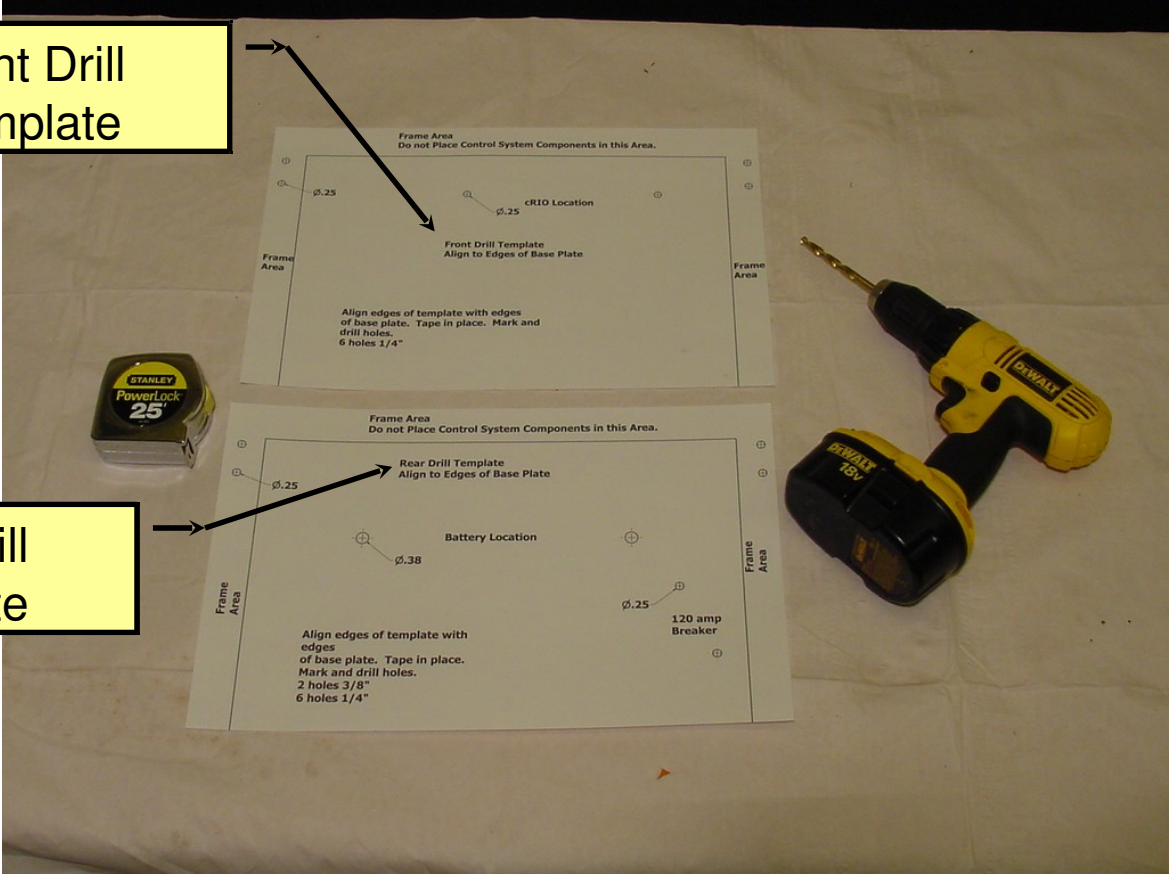

Rear Drill  
Template



Oklahoma  
Robotics



# Drill Holes in Base Plate



Base Plate

Rear Drill  
Template

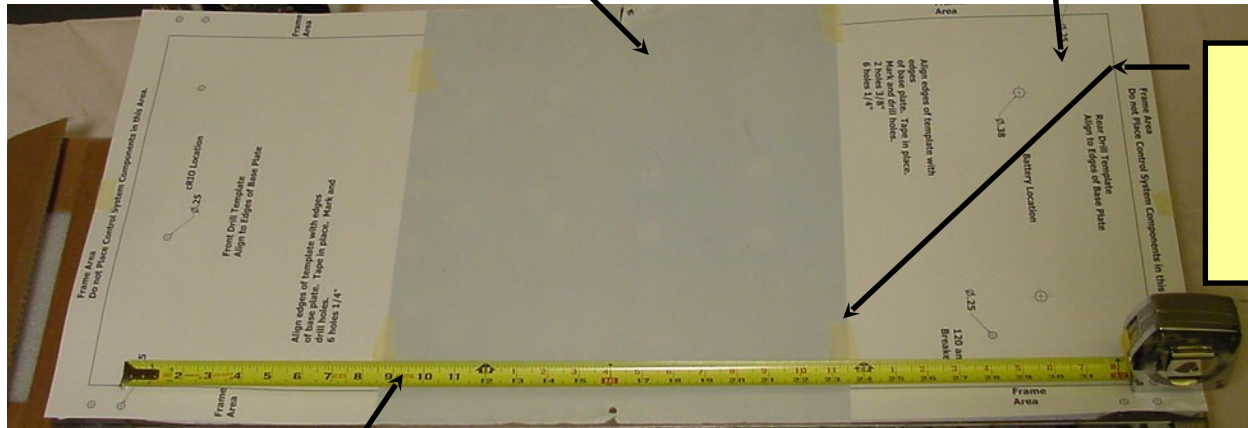

Tape Several  
Places to hold  
Template in  
Place

Make Sure Holes  
on Both Edges  
are Spaced 32"  
Apart Before  
Taping

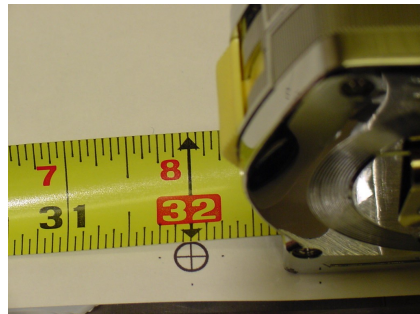
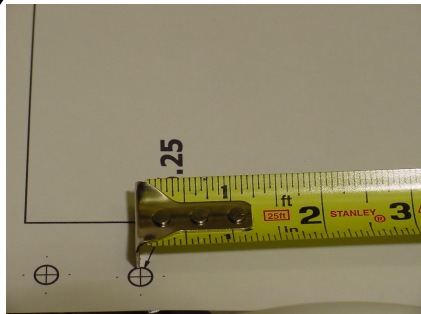

# Layout

 Layout the items similar to the picture.

 Leave 1-1/4" margin around all edges.  
This is the frame mounting area.

These Holes will  
be Matched  
Drilled After  
Installing on the  
Frame

Velcro

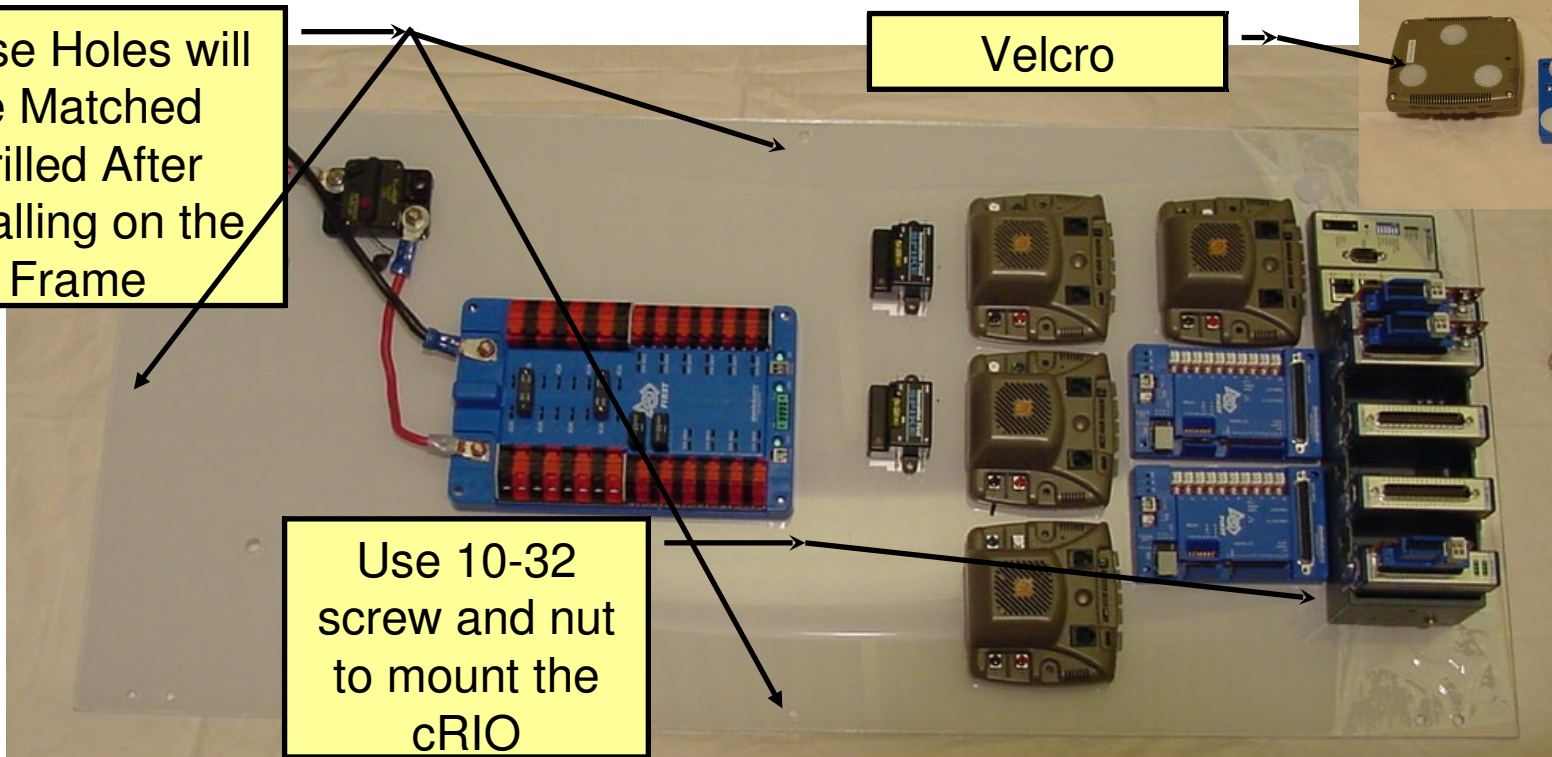
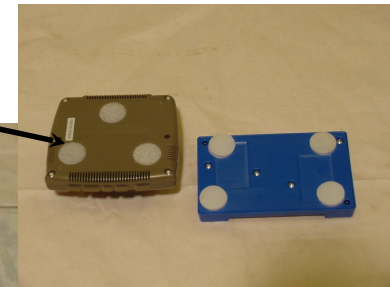

Use 10-32  
screw and nut  
to mount the  
cRIO

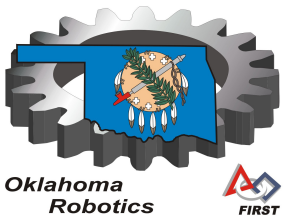



# Wiring



-  Wire the large battery wires. The black wire is connected directly from the half connector to the PD (power Distribution) board.
-  The red wire from the half connector is attached to the 120 amp circuit breaker and then on to the PD board.
-  Note: the 120 amp breaker uses SAE threads while the PD board uses Metric threads. Do not swap the nuts!



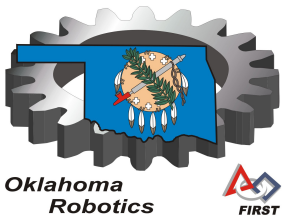

# Wiring



 Make the connections as shown below.

 Use the large terminals. Make good crimps.

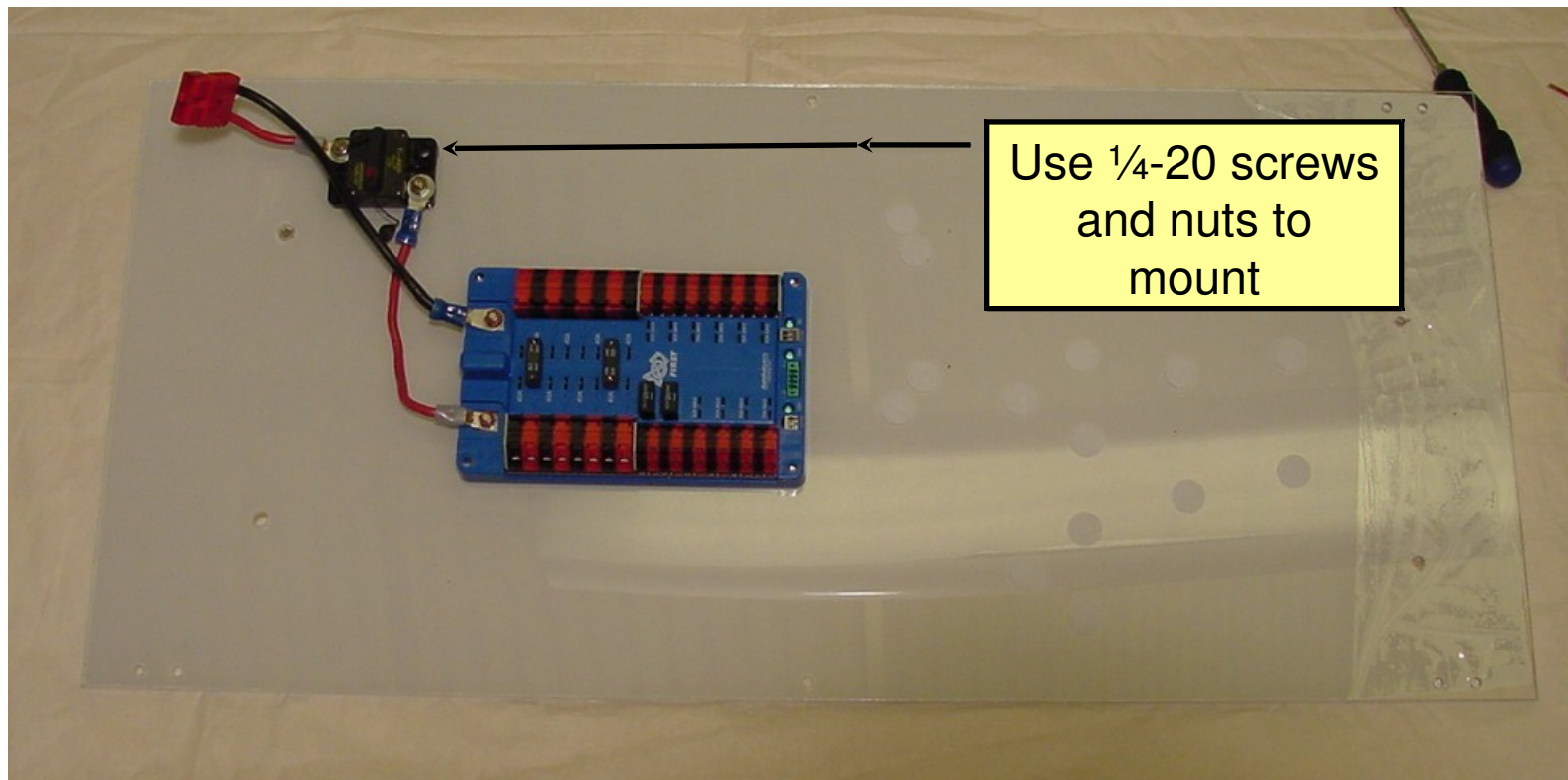

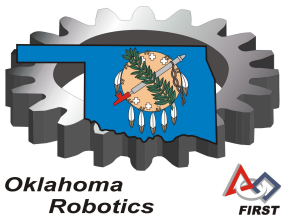

# Wiring



 Locate and install the DB37 cables.

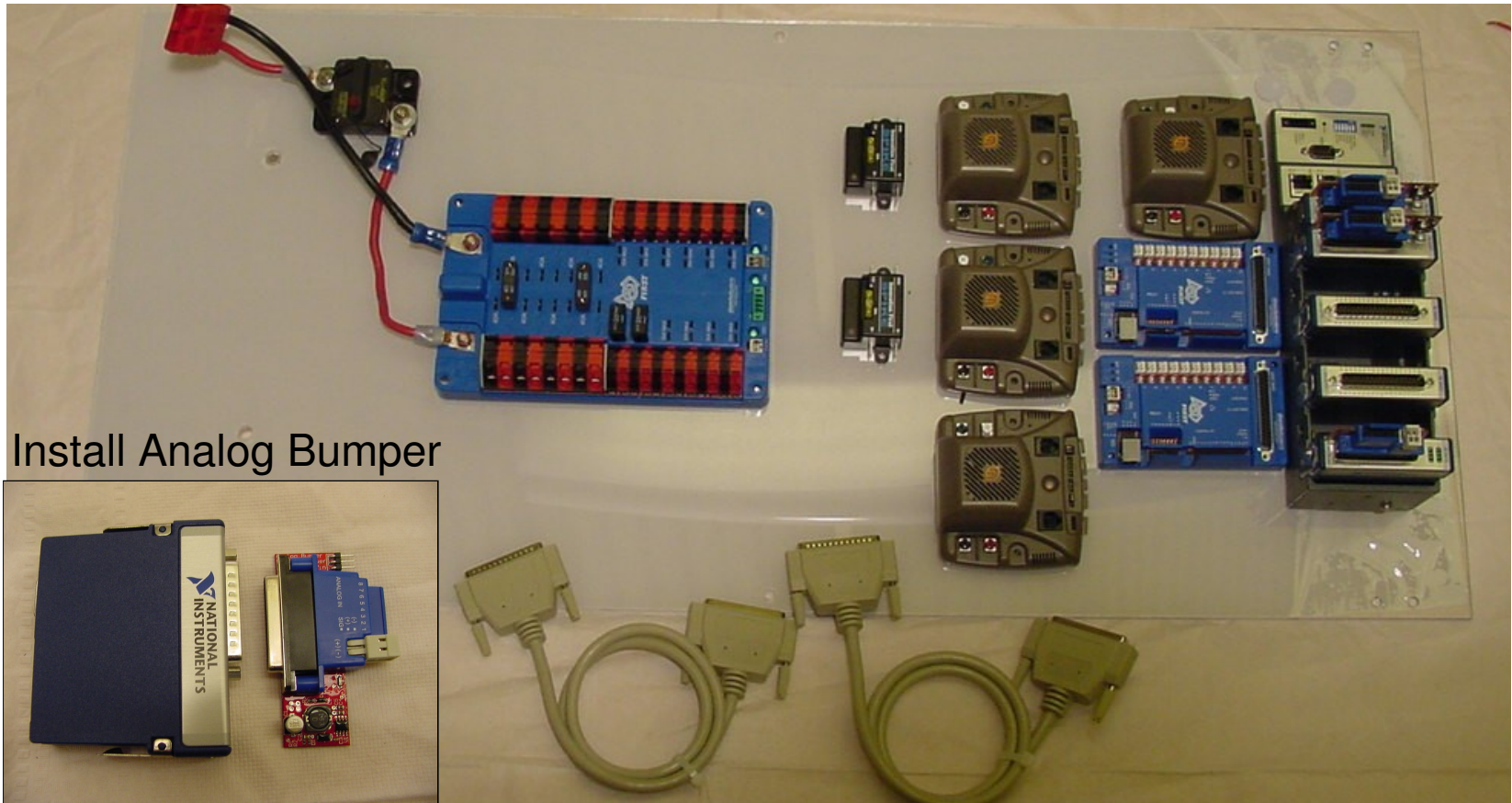



# Wiring

 Assemble the power cable for the cRIO.  
(#16 AWG)

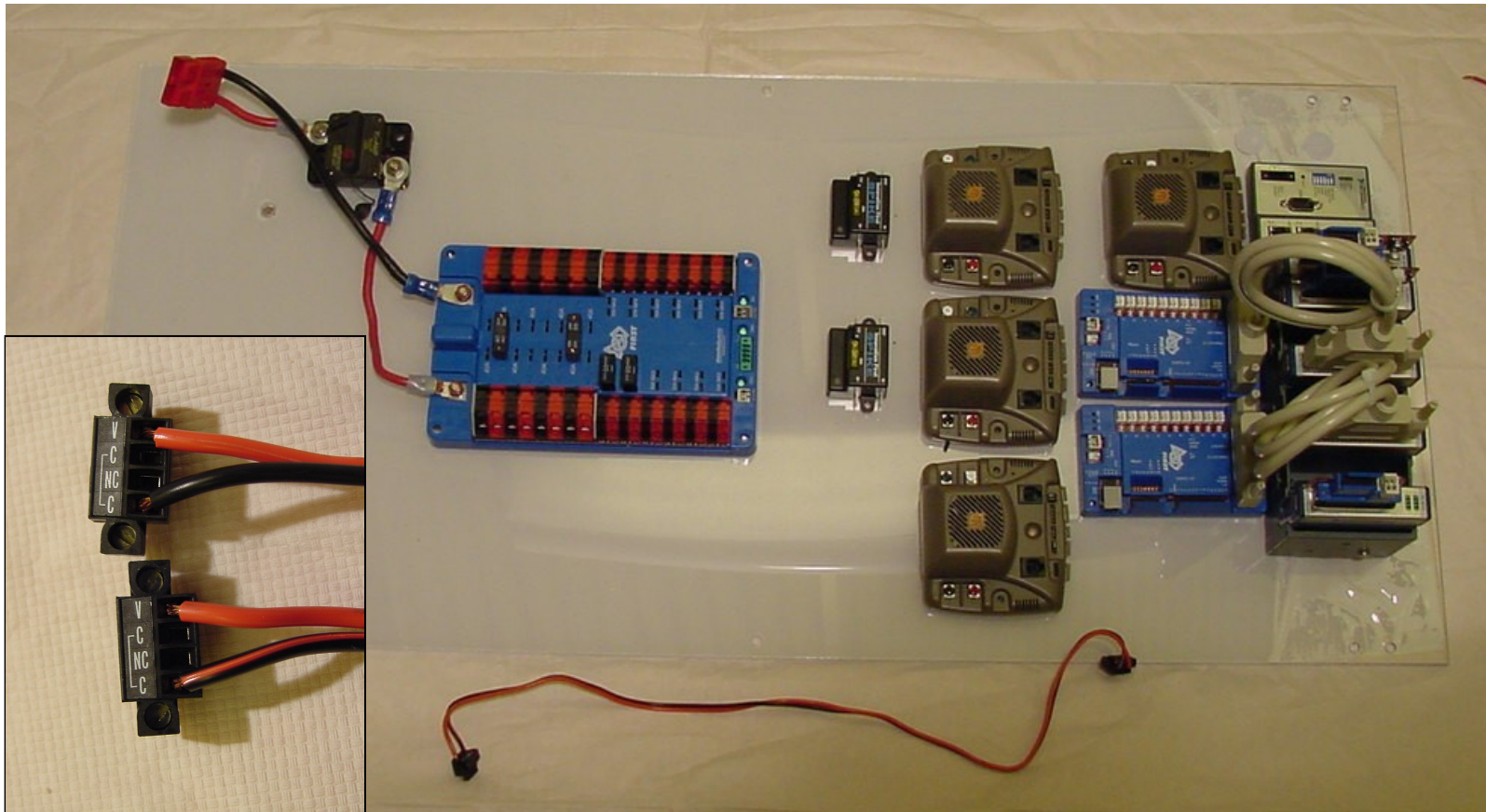





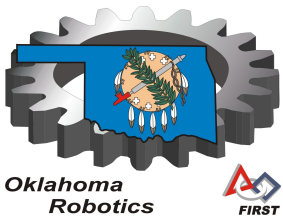

# Wiring



 Attach DSC cables to PD board.

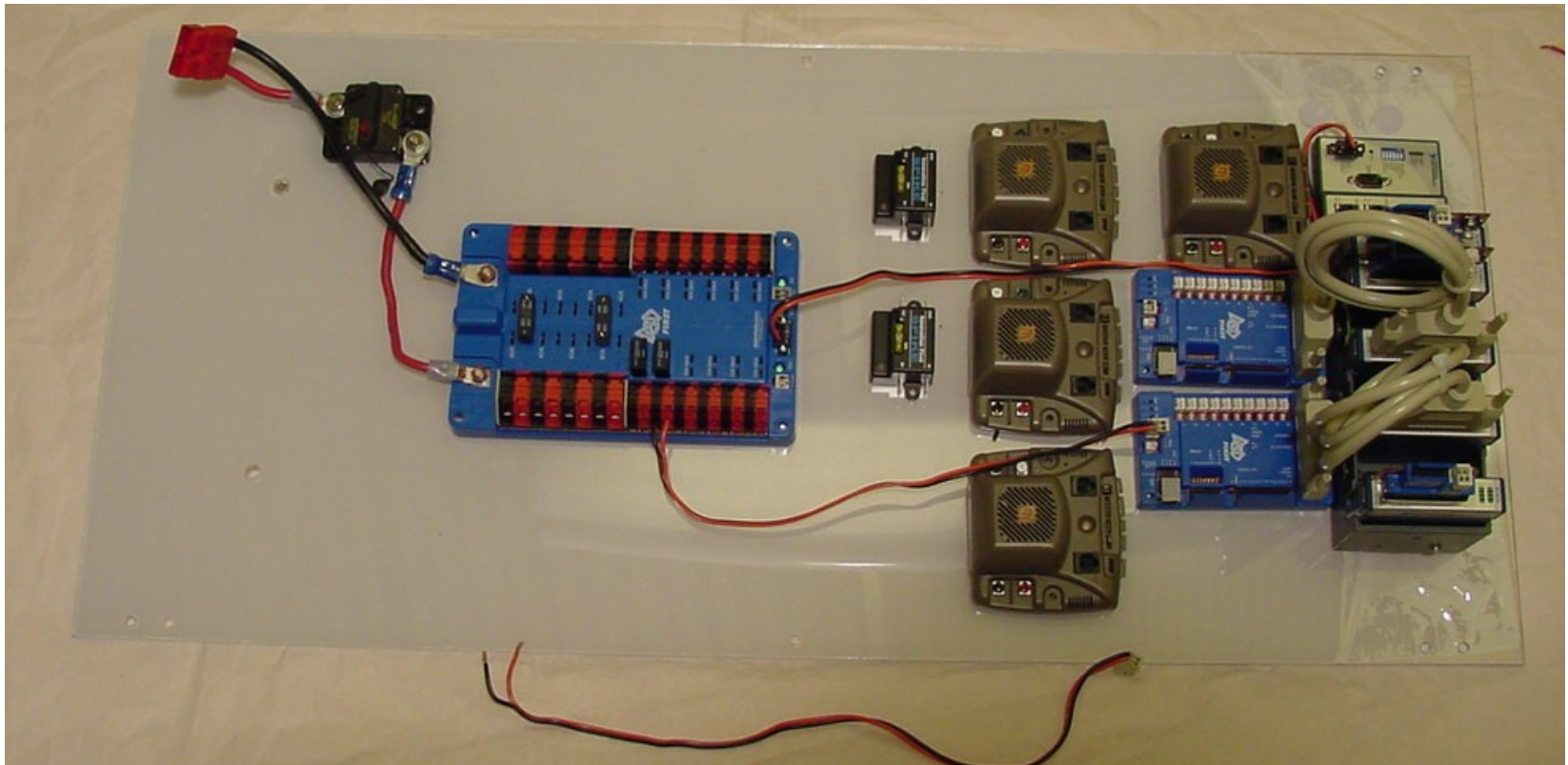

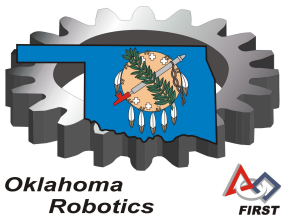

# Wiring



 Make power wires for Jaguar, 2 sets.  
(#10 AWG)

 Crimp supplied connectors to one end.

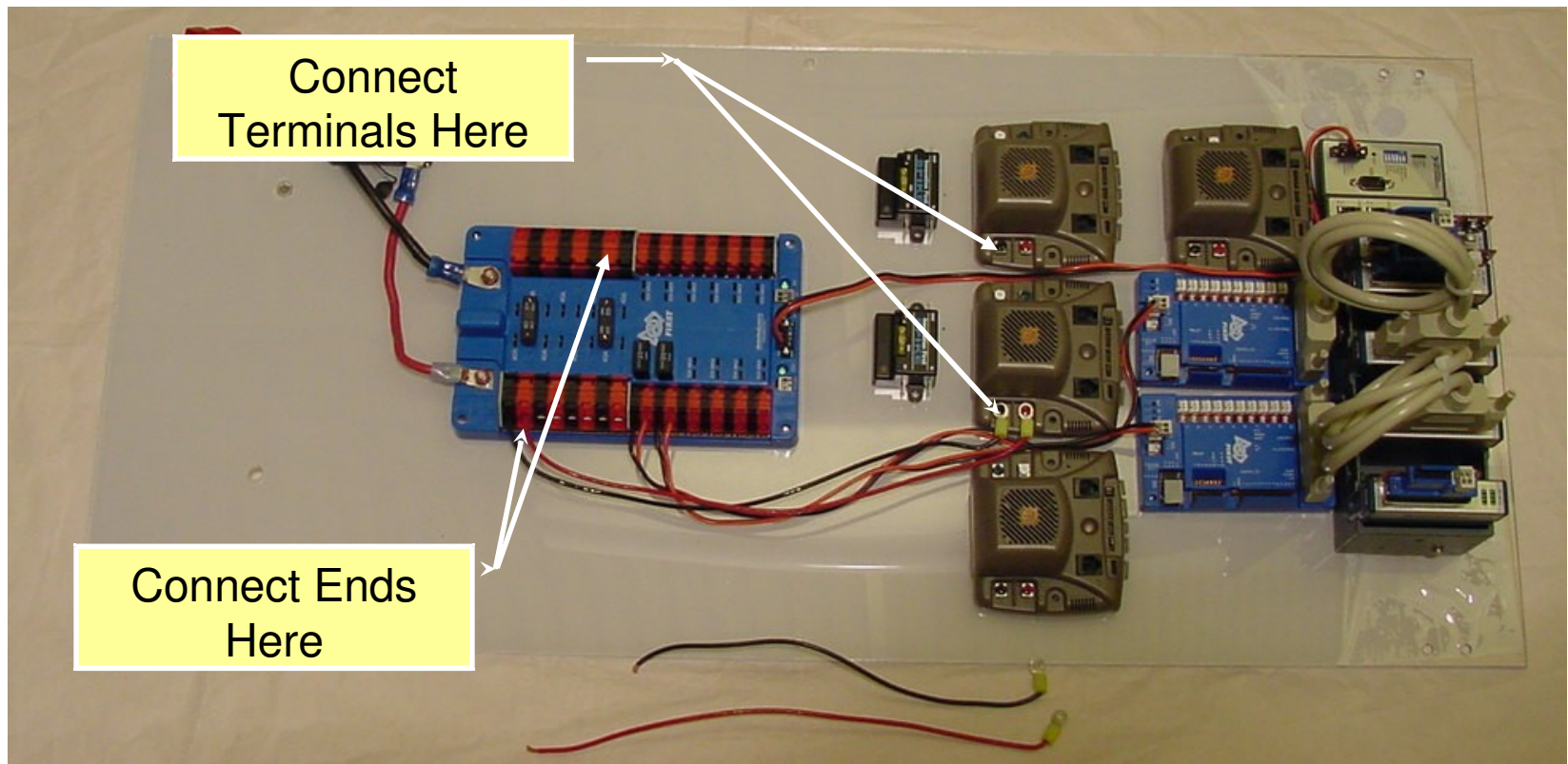

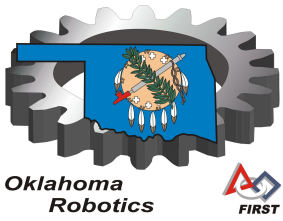

# Wiring



 Prepare 2 PWM Wires. The protective casing must be removed from one end.

 Refer to official PWM cable modification document.

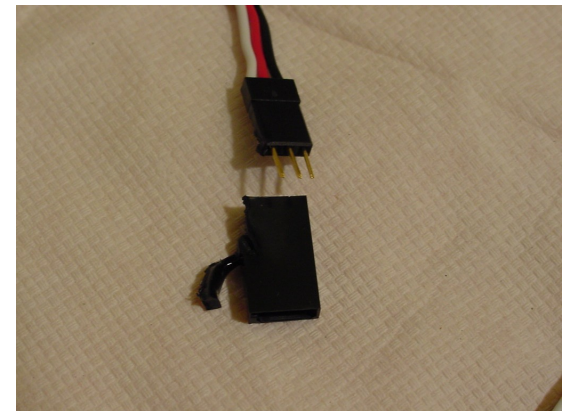
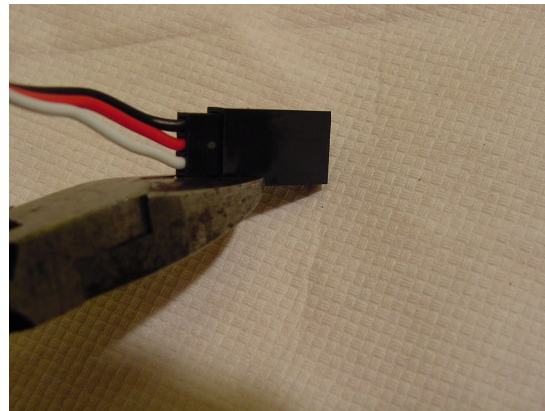
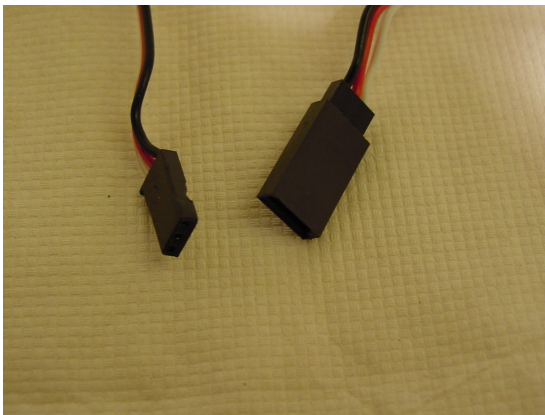



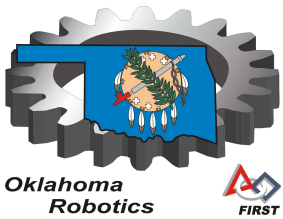

# Wiring



 Install PWM cables as indicated.

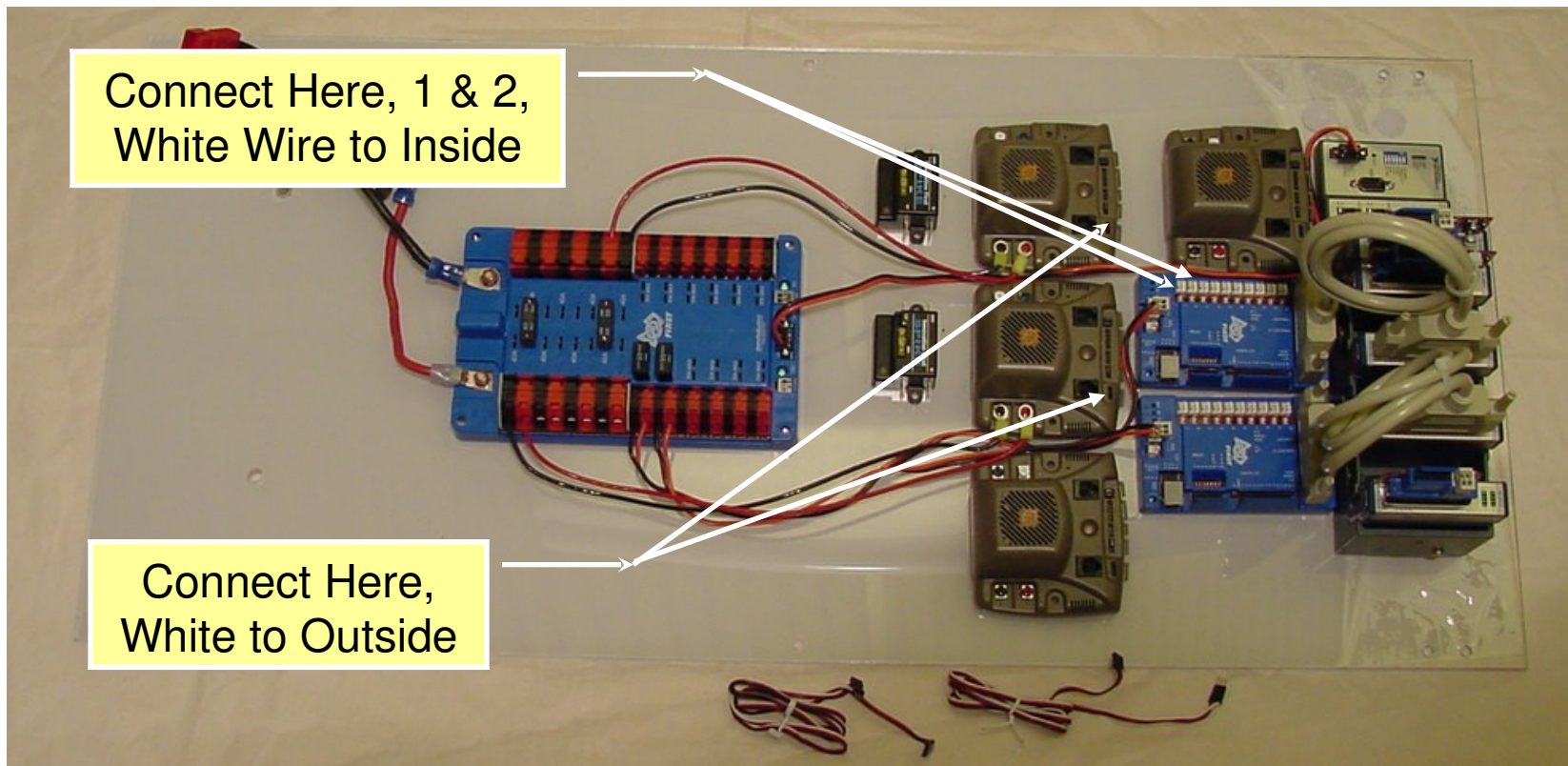



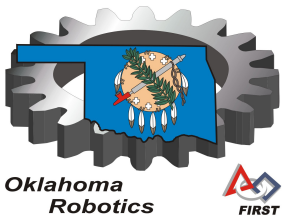

# Wiring



 The wiring of the control system bench test is complete. The final step is connecting 2 CIM motors to the Jaguars.

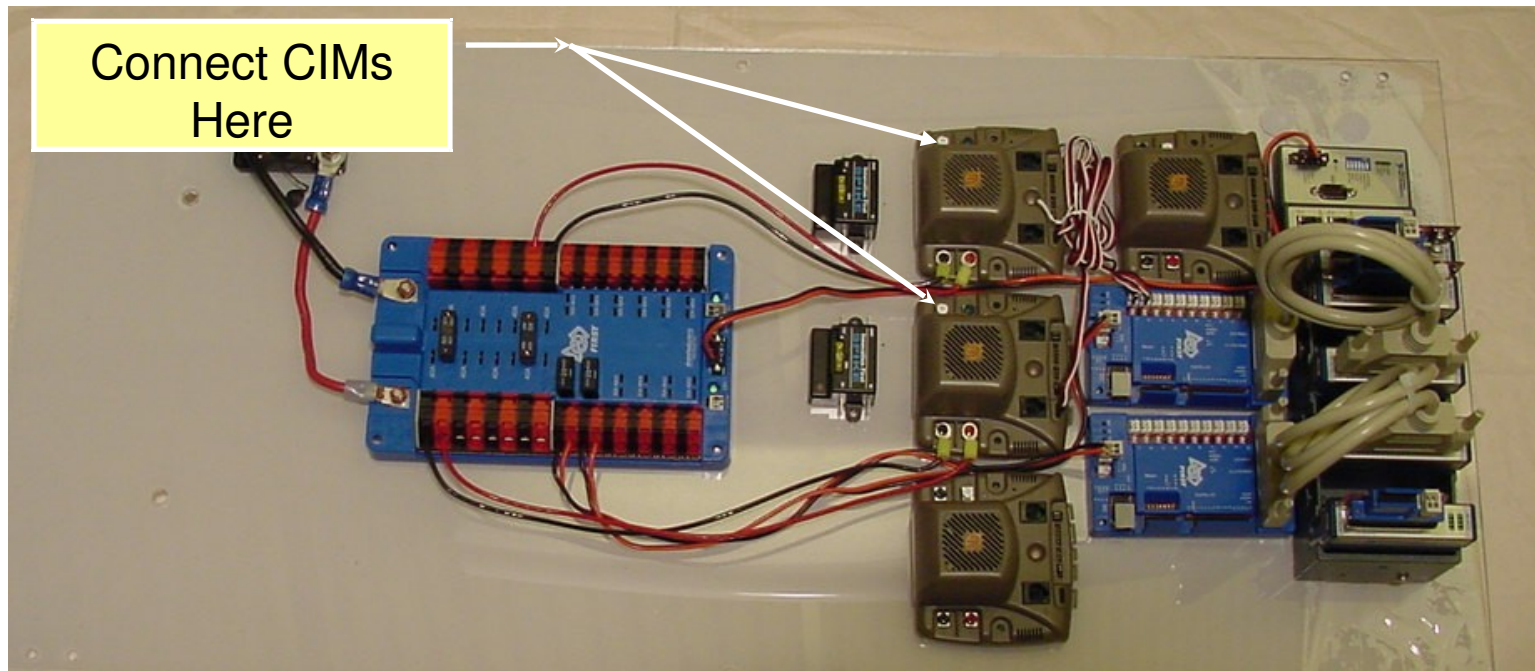

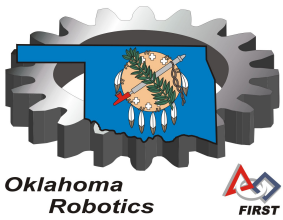

# Wiring Drivers Station (DS)



Connect the DS as shown below.  
Joysticks plug into USB 1 & 2.

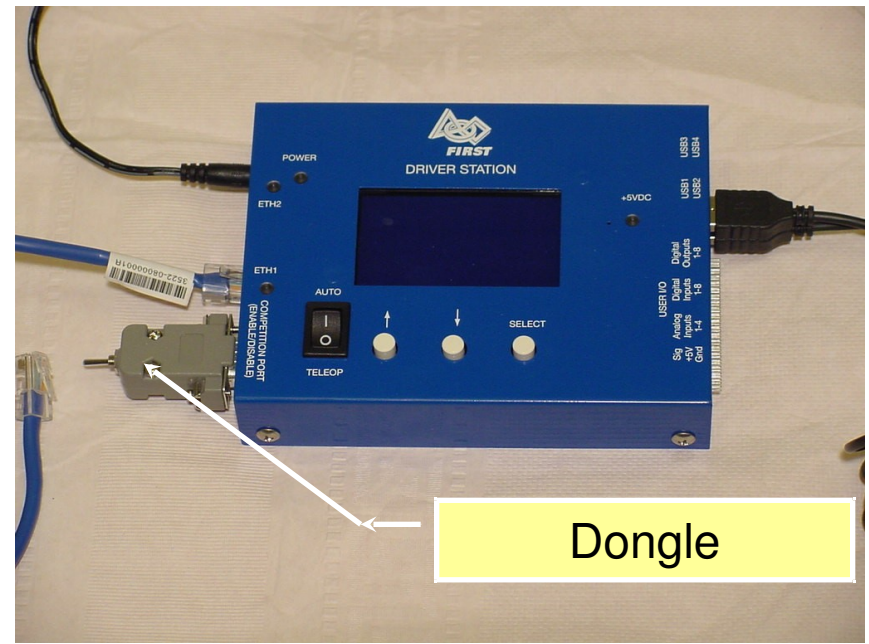

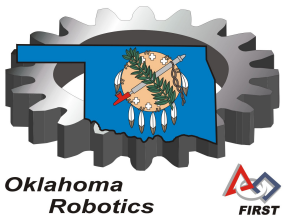

# Wiring Drivers Station (DS)



 Mount Drivers Station components to base using hook and loop dots.

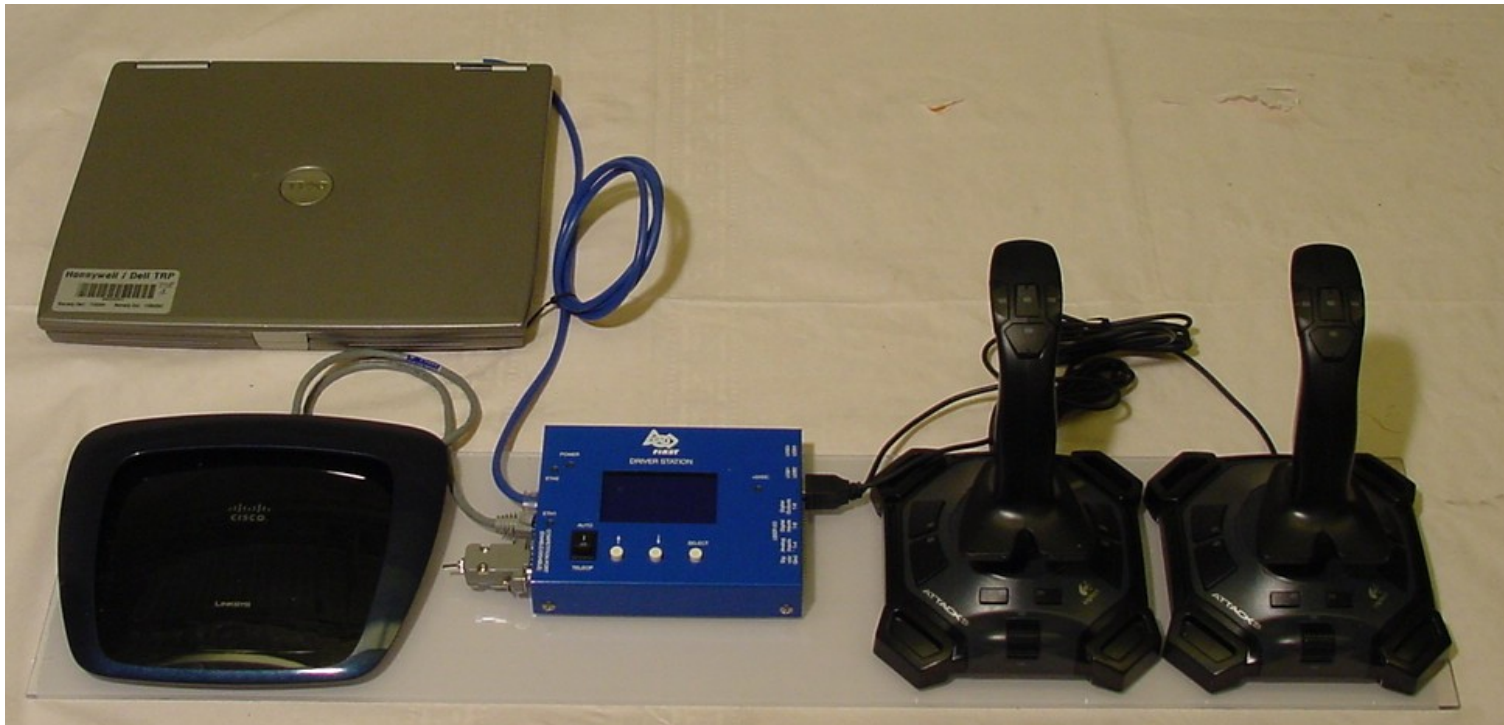



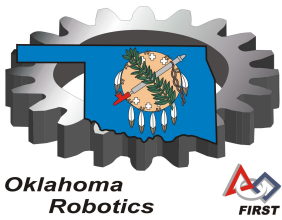





# Tethered Wiring



-  Connect the blue Ethernet cable from the DS to the cRIO port.
-  Put 120 amp breaker in off position.
-  Connect battery.  
Leave main breaker off.
-  Plug in wall wart for DS and power DS.

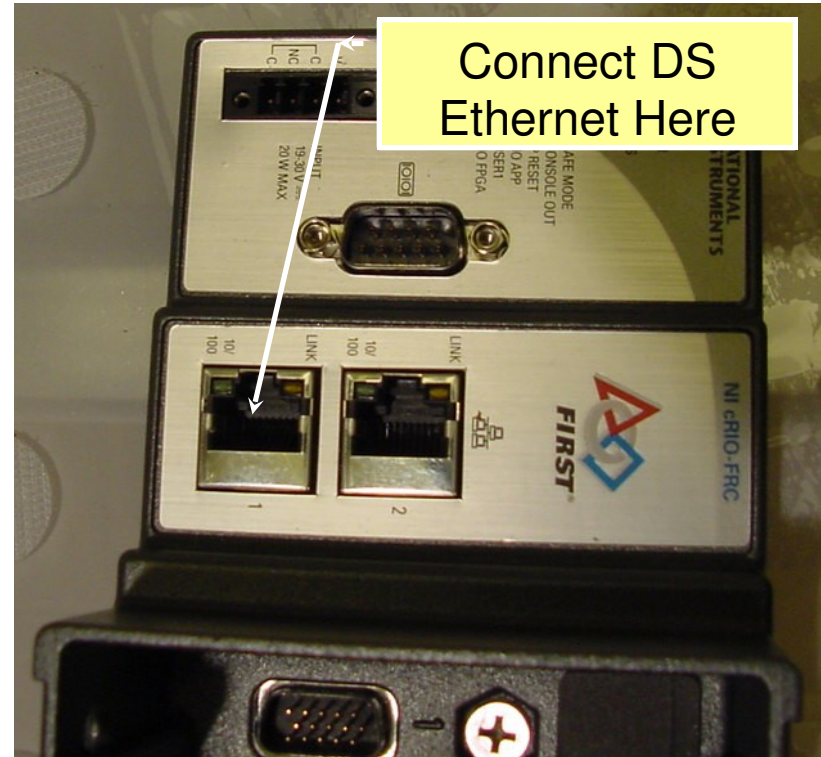

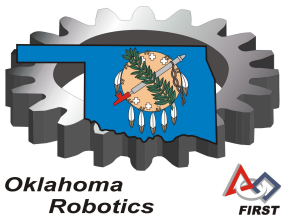

# Wireless Wiring?



 Follow section 2.3.2 of the FRC Control System Manual.

 The power wires to the wireless bridge need to be modified.

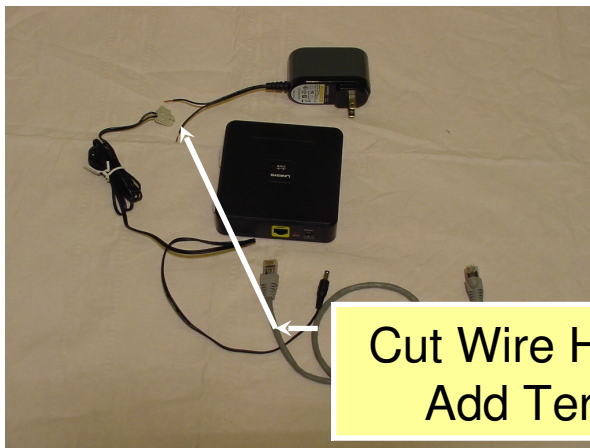

Cut Wire Here and Add Terminal

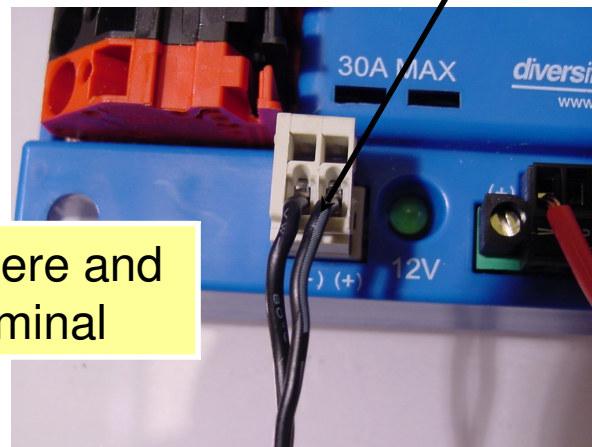

Black w/ white stripe



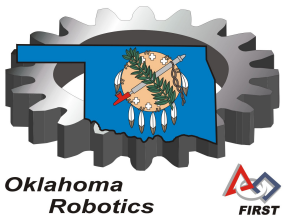

# Wireless Setup



 Mount wireless bridge and install modified power wire. (Frame included for reference.)

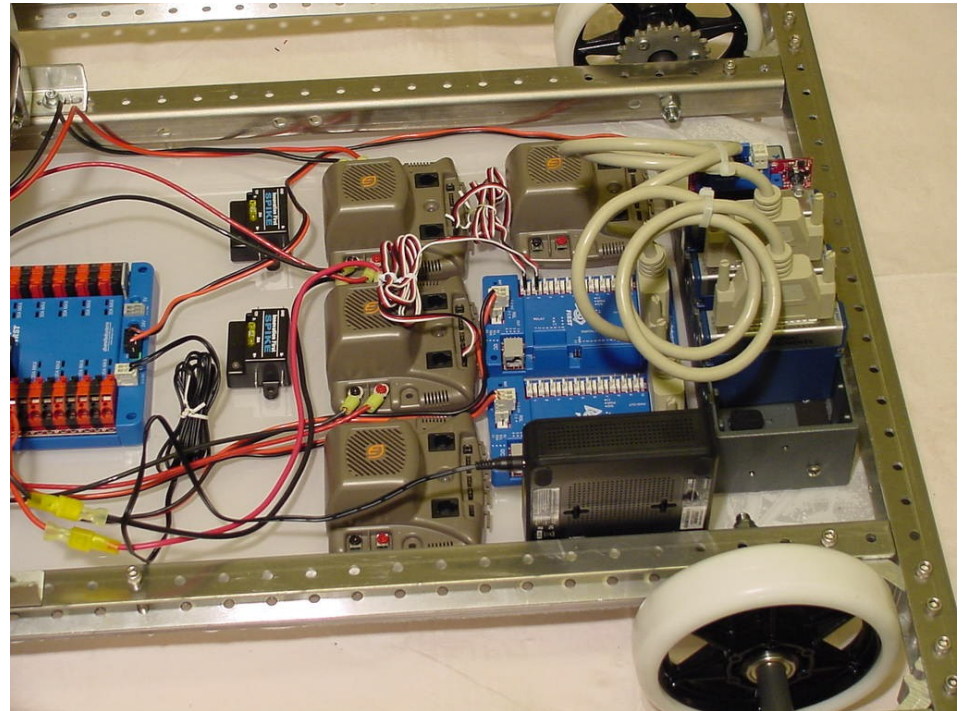



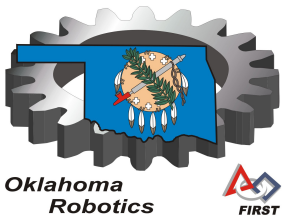





# Bench Test



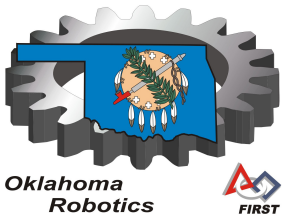

-  You are now ready to proceed with section 2.2.4 of the 2009 FRC control system manual.
-  Test the DS as per section 2.2.4
-  Test tethered operation as per section 2.3. You will not have motors at this point but can watch the lights on the Jaguar controllers to verify operation.
-  **You should be joined at this point by members of the programming team with the laptop.**
-  After successful tethered test, set up system for wireless operation.



# Wireless Setup



-  At this point you are ready to configure your wireless system. You must follow the instruction carefully.
-  Refer to the FRC Checklist by Benjamin Heavilin and the FRC 2009 Control System Manual. **(This will take about an Hour)**
-  After completion your system should operate wirelessly.



Oklahoma  
Robotics



# Install Base Plate onto Kitbot Frame



 Report back to the frame assembly area to verify they are ready for the base plate installation.

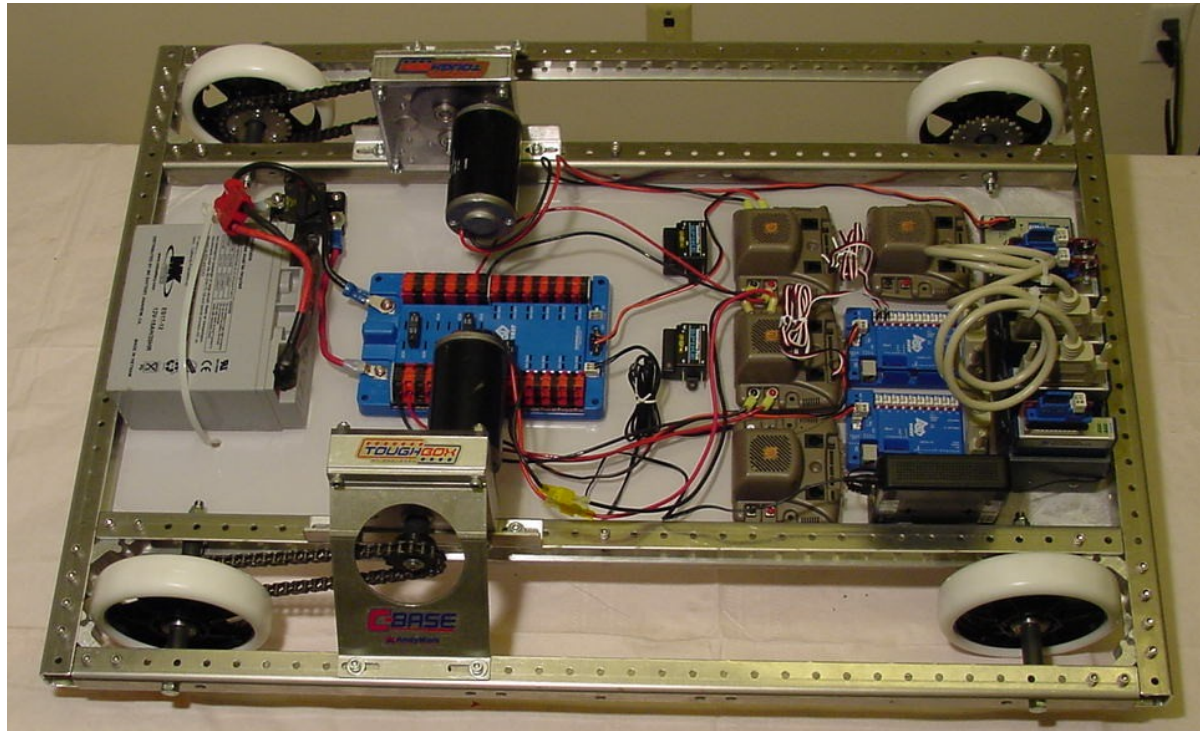

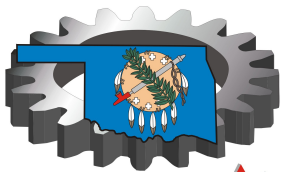

Oklahoma  
Robotics



# Install Base Plate onto Kitbot Frame



 Match drill three  $\frac{1}{4}$ " holes and install 1- $\frac{3}{4}$ " long bolts and nuts.

Match drill base plate at these locations and install the 3 bolts

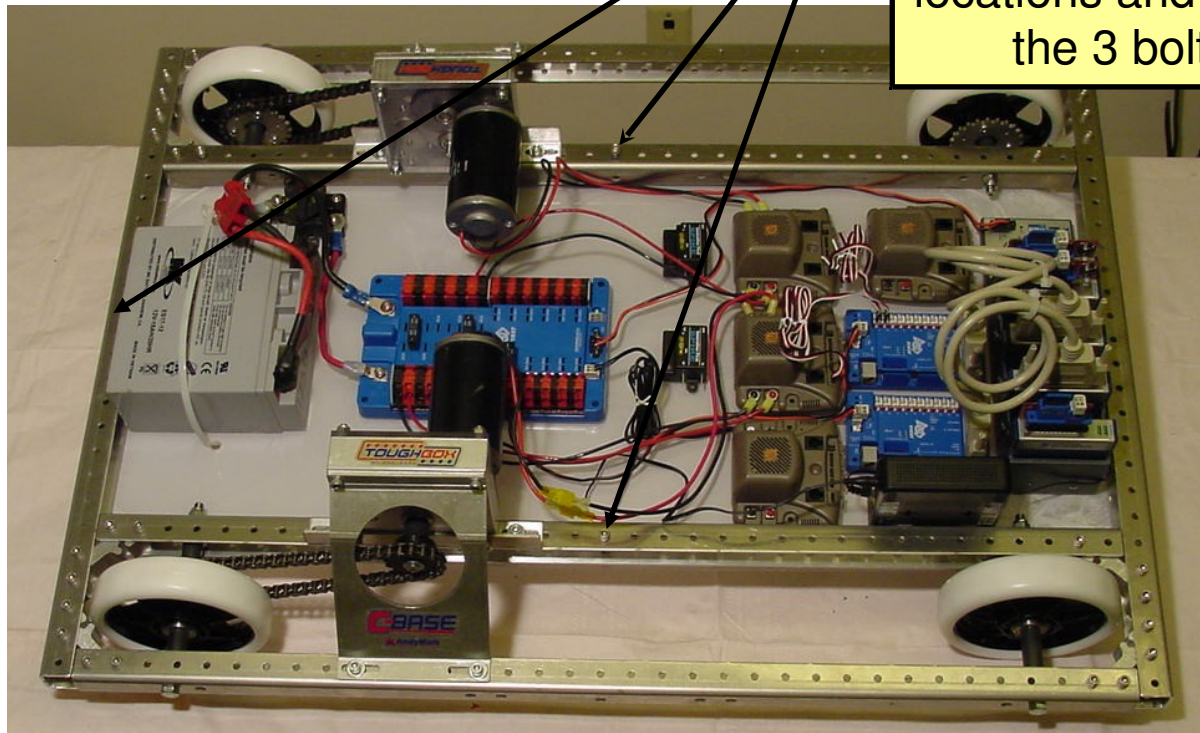

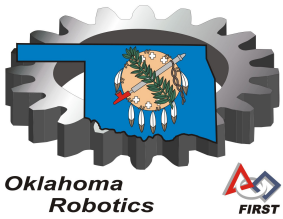

# Complete Tests



 Complete any remaining bench test not finished in the previous slides.

 **AT THIS POINT, THINGS CAN MOVE! BLOCK THE WHEELS OFF THE TABLE.**

 **MAKE SURE NOTHING IS IN THE CHAIN AREA OR CAN GET CAUGHT IN THE CHAIN.**

 **KEEP ALL PERSONNEL CLEAR OF THE CHAIN!**



# Programming



 Download the supplied default program to the cRIO.

 Bench test the program.

 Go to drive area.

 **CONGRATULATIONS!!!**